

**70 AND 80 SERIES
OILLESS ROTARY VANE
VACUUM PUMPS & COMPRESSORS
OPERATION & MAINTENANCE MANUAL**



CONTENTS:

General Information and Installation 2

Operation, Performance, and Maintenance & Inspection..... 3

Shut-Down Procedures and Service Kit Installation 4

Relief Valve Recommendations 5

70 Series Exploded View and Parts Ordering Information 6-7



80 Series Exploded View and Parts Ordering Information 8-9

Troubleshooting, Accessories/Kits, and Authorized Service Facilities 12







This is the hazard alert symbol:  When you see this symbol, be aware that personal injury or property damage is possible. The hazard is explained in the text following the symbol. Read the information carefully before proceeding.

The following is an explanation of the three different types of hazards:

-  **DANGER** Severe personal injury or death will occur if hazard is ignored.
-  **WARNING** Severe personal injury or death can occur if hazard is ignored.
-  **CAUTION** Minor injury or property damage can occur if hazard is ignored.

GENERAL INFORMATION



This pump is only to be used for the purpose of pumping air and under no circumstances be used with any other gases. The pump must not be used for the pumping of fluids, particles, solids or any substance mixed with air, particularly combustible substances likely to cause explosions.

-  **DANGER** Do not pump flammable or explosive gases or operate the unit in an atmosphere containing them.
-  **CAUTION** The exhaust air of this pump can become very hot. Do not direct exhaust air towards property that is temperature sensitive.
-  **CAUTION** The pump is designed for air only. Do not allow corrosive gases or particulate material to enter the pump. Water vapor, oil-based contaminants, or other liquids must be filtered out.
-  **CAUTION** Ambient temperature should not exceed 40°C (104°F). For operation at high temperatures, consult the factory.

Performance is reduced by lower atmospheric pressure found at high altitudes. Consult a Gast distributor for details.

Never lubricate this oil-less pump. The sealed bearings are grease-packed. The service life of the carbon vanes will be reduced by petroleum or hydrocarbon products.

INSTALLATION

-  **CAUTION** Do not lift the unit by the front shroud. The unit should be lifted by means of the eye bolt.
-  **WARNING** To avoid risk of electrocution do not use this product in an area where it could come in contact with water or other liquids. If exposed to the elements it must be weather protected.
-  **CAUTION** Do not block the flow of cooling air over the pump in any way.

MOUNTING THE PUMP

The pump may be installed in any orientation as long as the flow of cool, ambient air over the pump is not blocked. To reduce noise and vibration, mount to a stable, rigid operating surface.

For units supplied with an adapter plate (see pgs. 6 & 7) be careful to securely attach plate to both motor and unit; be sure the casting numbers on plate are positioned at top. Attach adapter plate to motor with four (4) socket head cap screws, then attach this to pump with four (4) fasteners supplied with adapter plate.

PLUMBING

To prevent airflow restriction, use pipe and fittings that are the same size or larger than the threaded ports of the pump. The ports are marked "vacuum" or "pressure".

NOTE: The exhaust on vacuum pumps and inlet on pressure pumps is through the small holes in the muffler box cover (2 holes on the 70 Series, 3 holes on the 80 Series).

ACCESSORIES

Intake and exhaust filters are internal to the pump and will provide adequate filtration for most applications. Check filters periodically and replace when necessary. Consult a Gast representative for additional filter recommendations. Install relief valves and gauges at the inlet or outlet, or both, to monitor performance. Check valves may be required to prevent backstreaming through the pump. See Accessory/Kit section on page 4.

WIRING

-  **WARNING** Incorrect wiring can result in electric shock. Wiring must conform to all required safety codes and be installed by a qualified person. Grounding is required. All power to the motor must be de-energized and disconnected when servicing.

ELECTRIC MOTOR CONTROL

The motor must be protected against short circuit, overload and excessive temperature rise. Fuses, motor protective switches and thermal protective switches provide the necessary protection in these circumstances. Fuses only serve as a short circuit protection of the motor (wiring fault), not as a protection against overload. Fuses in the incoming line should be chosen so as to be able to withstand the starting current of the motor. Motor starters, incorporating thermal magnetic overload or circuit breakers protect the motor from overload or reduced voltage conditions. Selection of the correct overload setting is required to provide the best possible protection. Refer to the manufacturer's motor starter recommendations.

ELECTRIC MOTOR CONNECTION

Refer to the motor nameplate for wiring diagram. All dual-voltage motors are shipped from the factory wired for high voltage. If the motor fails to start or slows down under load, shut the pump off and unplug it. Check that the supply voltage agrees with the motor nameplate. Be sure the 3-phase motor turns in the proper direction of rotation after installation. Turning in the wrong direction will drastically reduce vane life.

OPERATION

- ⚠ WARNING** Solid or liquid material exiting the unit can cause eye or skin damage. Keep away from air stream.
- ⚠ WARNING** Always disconnect the power before servicing. The motor may be thermally protected and will restart automatically when it cools if the thermal protection switch is tripped.
- ⚠ WARNING** Do not operate without both the coupling guard and shroud in place. Failure to do so could result in severe personal injury.
- ⚠ CAUTION** Do not operate units above recommended pressures or vacuum duties. To do so will damage the unit.

STARTING

If the pump is extremely cold, let it warm up to room temperature before starting. If the pump does not operate properly, see the troubleshooting guide (pg. 4).

PERFORMANCE

Recommended duty ranges are as follows:

Compressors up to 15 PSI.

Vacuum Pumps up to 25-26" Hg (depending on model).

Dual Function Models for 80 Series - 9 PSI, 18" Hg.

Dual Function Models for 70 Series - 5 PSI, 15" Hg.

MAINTENANCE and INSPECTION

Regular inspection can prevent unnecessary damage and repairs. The internal intake and exhaust filters require periodic inspection and replacement. Initial inspection is suggested at 500 hours, then the user should determine the frequency. Most problems can be prevented by keeping filters clean. Dirty filters decrease pump performance and can decrease pump service life. Filters are accessed by removing filter box covers.

FILTER INSPECTION/REPLACEMENT

- ⚠ WARNING** The exhaust muffler and muffler box cover may become very hot during operation. Do not touch these parts until the pump has been turned off and allowed to cool.

Refer to exploded view drawing during the following procedure. With the pump turned off and isolated from the power supply, and all pressure and/or vacuum is released from the pump, remove four retaining screws from the filter cover. Lift off the filter cover (a flat blade of a screw driver maybe required to break the gasket seal), and inspect for contamination, this will be black vane dust or dirt. If the filter is completely covered with contamination or has indicated an increase in differential pressure, it must be replaced. Replace or renew the filter, taking care to locate the cartridge in the correct position within the casting. Refit the cover and replace the gasket if it is broken or deformed. Install and tighten the screws. Before putting the pump back into service, ensure that any external accessories such as relief valves and gauges attached to the cover have not been damaged.

FLUSHING

Flushing may be required to remove foreign material that accumulates in the pump and causes the vanes to stick. Several teaspoons of flushing solvent should be introduced into the intake port while the pump is running.

SHUT-DOWN PROCEDURES

Proper shutdown procedures must be followed to prevent pump damage. Failure to do so may result in premature pump failure. The Gast Manufacturing Rotary Vane Non-Lubricated vacuum pumps and compressors are constructed of ferrous metals or aluminum which are subject to rust and corrosion when pumping condensable vapors such as water.

Follow the steps below to assure correct storage and shut-down between use:

1. NEVER oil this non-lubricated pump.
2. After using the pump, disconnect plumbing and allow the pump to run "open" for at least 5 minutes before shut-down.
3. Plug the open ports to prevent dirt or other contaminants from entering the pump. It is now ready for shut-down or storage.

Troubleshooting Guide

Reason for Problem	Vacuum Low	Vacuum High	Pressure Low	Pressure High	Pump Overheating	Motor Overload
Filter dirty	X		X		X	X
Muffler dirty			X		X	X
Vacuum line collapsed	X				X	X
Relief valve set too high		X		X	X	X
Relief valve set too low	X		X		X	X
Plugged vacuum or pressure line	X			X	X	X
Vanes sticking	X		X			
Running at too high RPM		X		X	X	X
Vanes worn (Replace)	X		X			
Shaft Seal worn (Replace)	X		X			
Particulate material in pump	X				X	X
Motor not wired correctly	X		X			X

ACCESSORIES/KITS



Gauges

Vacuum Gauge AA640
(1/4" NPT, Bottom Mounted)

Vacuum Gauge AE136
(1/4" NPT, Back Mounted)

Pressure Gauge AA644B
(1/4" NPT, Bottom Mounted)

Pressure Gauge AN190
(1/4" NPT, Back Mounted)

Relief Valves

Vacuum Relief Valve AN226
(3/4" NPT, 15-55 cfm)

Vacuum Relief Valve AN226A
(3/4" BSP, 25-93 m3/h)

Pressure Relief Valve AN225
(3/4" NPT, 15-45 cfm)

Pressure Relief Valve AN225A
(3/4" BSP, 25-76 m3/h)

Pressure Relief Valve AN225B
(3/4" NPT 45-75 cfm)

Pressure Relief Valve AN225C
(3/4" BSP, 76-127 m3/h)

Filter/Muffler Kit

70 Series Vacuum Pumps
K561

70 Series Compressors
K563

70 Series Dual-Function Pumps
K565

80 Series Vacuum Pumps
K552

80 Series Compressors
K552

80 Series Dual-Function
Pumps K547

Complete Rebuild Kits

70 Series Vacuum Pumps
K560

70 Series Compressors
K562

70 Series Dual-Function
Pumps K564

80 Series Vacuum Pumps
K546

80 Series Compressors
K546

80 Series Dual-Function
Pumps K551

SERVICE KIT INSTALLATION

NOTE: Gast will not guarantee the performance of a field rebuilt pump. You can return the pump to a Gast authorized service facility, or perform the rebuild procedures described below.

Each service kit contains most or all of the following: bearings, vanes, gaskets, and filter elements (seen in Figure 1 below).

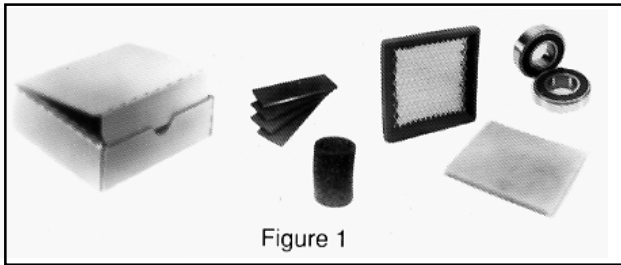

Figure 1

Follow these general steps to install the kit:

PUMP DISASSEMBLY:

1. Disconnect the pump from electrical power.

⚠ WARNING You must disconnect the pump from electrical power before servicing it. Failure to do so can result in severe personal injury or death.

2. Vent all air lines to the pump to remove pressure.

⚠ WARNING You must vent all air lines to the pump to remove pressure before servicing it. Failure to do so can result in severe personal injury.

3. Remove the shroud and fan.

4. Use a wheel puller to remove the dead-end plate and bearing from the pump body; note the direction of the bevel edge on the vane. Do not damage the dowel pins between the end plate and the body. Save the bearing spacer on the dead-end of the shaft for reassembly. Remove the snap ring from the end plate. Save the snap ring, Belleville springs, and washer for reassembly.

5. Remove the bearing from the dead-end plate.

6. Check the exposed surfaces of the rotor, body, and end plate for scoring.

- a. If you find no scoring, you can perform a Minor Rebuild to replace only the vanes and the dead-end bearing.

- b. If you find severe damage, perform the Major Rebuild.

MINOR REBUILD:

7. Install the new vanes supplied with the kit. Be careful to face the vane bevels in the proper direction (as noted in step 4).
8. Place end plate over the shaft with dowel pins aligned. Place bearing spacer on dead end of shaft. Place the new bearing in its bore in the dead end plate. Be careful to press only on the inner bearing race.
9. Install and tighten the pump body bolts. Install the Belleville springs with the washer between them, and the snap ring.

MAJOR REBUILD:

7. Remove the drive end cap. Use a wheel puller to remove the drive-end plate and bearing from the pump body. Do not remove or damage the dowel pins in the body. Save the bearing spacer and endplate gasket for reassembly.
8. Place one of the new bearings in its seat in the drive-end plate, then place one of the shoulder rings on the drive-end of the shaft. Using an arbor press, press the bearing onto the shaft. Be careful to press only on the inner bearing race. Tighten the pump body bolts.
9. Install the new vanes supplied with the kit. Be careful to face the vane bevels in the proper direction (as noted in step 4).
10. Perform step #8 from Minor Rebuild.
11. Install the Belleville springs with the washer between them, and the snap ring. Install and tighten the pump body bolts.
12. Apply a thread-lock adhesive and start the drive end cap into its thread in the drive end plate, but do not tighten it.
13. Place a dial indicator against the dead-end of the shaft to measure axial movement. Tighten the drive end cap until the indicator shows .002" to .0025" of the shaft movement against the Belleville springs.
14. Replace the filter elements.

70 Series Dual Function Shown

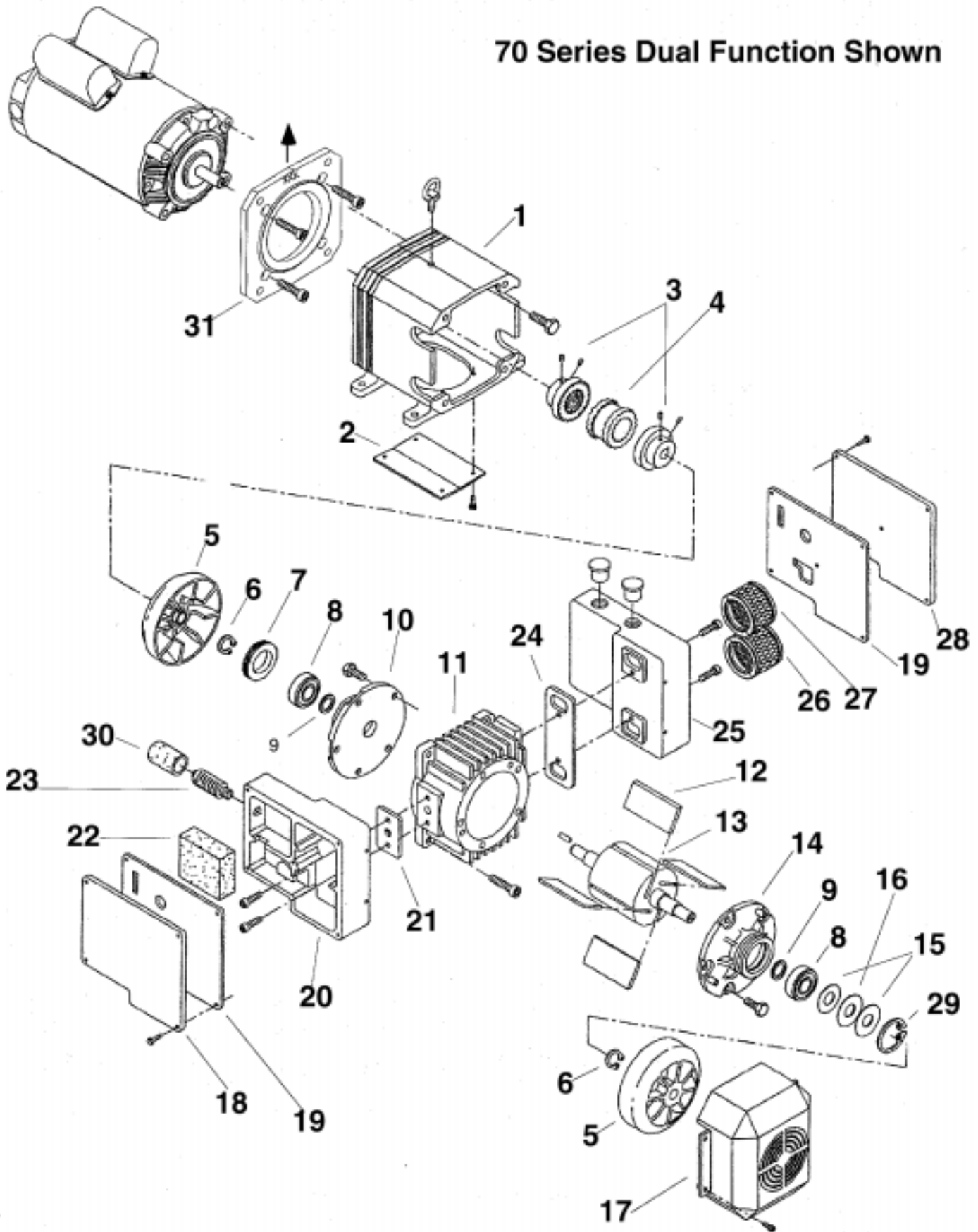

PARTS ORDERING INFORMATION FOR 70 SERIES MODELS

Ref No	Description	Qty	1070 Vacuum	2070 Vacuum	1070 Pressure	2070 Pressure	1070 Dual Function	2070 Dual Function
1	Foot Bracket Cover	1	AN173	AN173	AN173	AN173	AN173	AN173
2	Foot Bracket	1	AN171	AN171	AN171	AN171	AN171	AN171
3	Flange	2	AE545B	AE545B	AE545B	AE545B	AE545B	AE545B
4	Sleeve	1	AE546	AE546	AE546	AE546	AE546	AE546
5	Fan	2	AC326B	AC326B	AC326B	AC326B	AC326B	AC326B
6	Retainer Ring	2	AC447	AC447	AC447	AC447	AC447	AC447
7	Drive End Cap	1	AB339	AB339	AB339	AB339	AB339	AB339
*8	Bearing	2	AC894	AC894	AC894	AC894	AC894	AC894
9	Deflector	2	AH193	AH193	AH193	AH193	AH193	AH193
10	Drive End Plate	1	AN111	AN111	AN111	AN111	AN111	AN111
11	Body	1	AN100B	AN101B	AN100	AN101	AN100A	AN101A
*12	Vane	4/5	(5) AH195	(5) AH195	(4) AH195	(4) AH195	(4) AH195	(4) AH195
13	Rotor Assembly	1	AN121A	AN121A	AN121	AN121	AN121	AN121
14	Dead End Plate	1	AN111A	AN111A	AN111A	AN111A	AN111A	AN111A
15	Springs	2	AB337	AB337	AB337	AB337	AB337	AB337
16	Washer	1	AB338	AB338	AB338	AB338	AB338	AB338
17	Shroud	1	AN181	AN181	AN181	AN181	AN181	AN181
18	Muffler Box Cover	1	AN182D	AN182B	AN182A	AN182A	AN182	AN182
*19	Filter/Muffler Box Gasket	2	AN153	AN153	AN153	AN153	AN153	AN153
20	Muffler Box	1	AN152A	AN152A	AN152	AN152	AN152B	AN152B
21	Gasket	1	AN156	AN154	AN154	AN154	AN154	AN154
**22	Foam	1	----	----	----	----	AN158	AN158
**23	Pneumatic Muffler	1	----	----	----	----	AF353	AF353
24	Gasket	1	AN156A	AN155	AN155	AN155	AN155	AN155
25	Filter Box	1	AN151D	AN151D	AN151C	AN151C	AN151E	AN151E
**26	Filter (larger)	1	AN156	AN156	AN156	AN156	AN156	AN156
**27	Filter (smaller)	1	AN157	AN157	AN157	AN157	AN157	AN157
28	Filter Box Cover	1	AN182E	AN182	AN182	AN182	AN182E	AN182
29	Retainer Ring	1	AB335	AB335	AB335	AB335	AB335	AB335
**30	Filter Felt	1	----	----	----	----	AK335	AK335
31	Adapter Plate	1	AN175	AN175	AN175	AN175	AN175	AN175
†	Repair Kit	1	K560	K560	K562	K562	K564	K564
*	Filter/Muffler Kit	1	K561	K561	K563	K563	K565	K565

ACCESSORIES

	Vacuum Relief Valve	1	AN226	AN226	----	----	AN226	AN226
	Pressure Relief Valve	1	----	----	AN225	AN225	AN225	AN225
	Pressure Gauge	1	----	----	AN190	AN190	AN190	AN190
	Vacuum Gauge	1	AE136	AE136	----	----	AE136	AE136

Part numbers listed are for stock model units. For specific OEM models consult the factory.

Accessories listed are not shown in exploded view.

---- Not applicable

† Reflects parts included in the Repair Kit

* Reflects parts included in the Filter Replacement Kit

80 Series Dual Function Shown

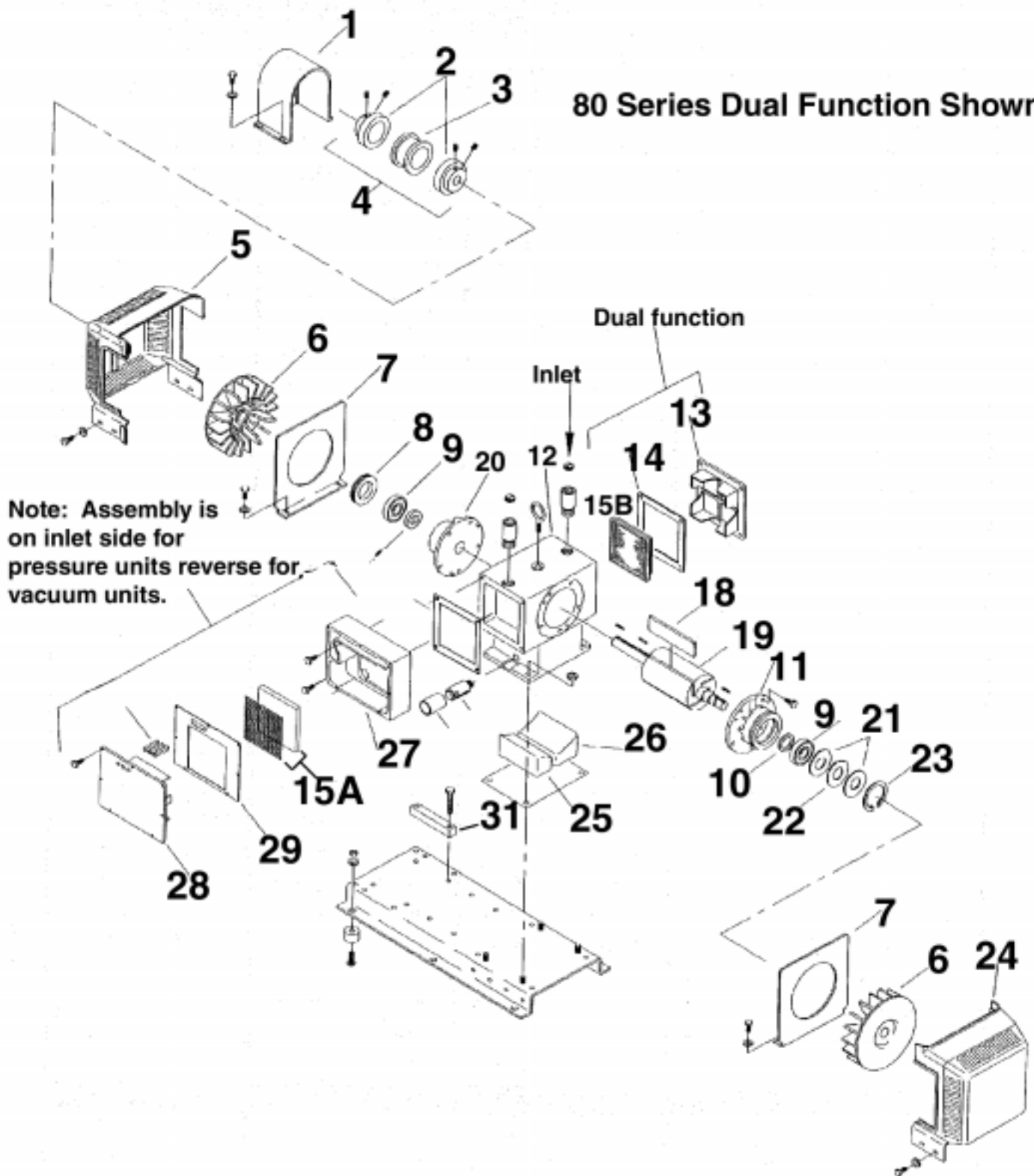

PARTS ORDERING INFORMATION FOR 80 SERIES MODELS

Ref No	Description	Qty	Vacuum Pumps			Compressors			Dual Function		
			2080	3080	4080	2080	3080	4080	2080	3080	4080
1	Coupling Guard	1	AE973B	AE973B	AE973B	AE973B	AE973B	AE973B	AE973B	AE973B	AE973B
2	Flange	1/2	2-AE547A ----	2-AE547A ----	1-AE547A 1-AE547C	2-AE547A ----	1-AE547A 1-AE547C	1-AE547A 1-AE547C	2-AE547A ----	1-AE547A 1-AE547C	1-AE547A 1-AE547C
3	Sleeve	1	AE548	AE548	AE548	AE548	AE548	AE548	AE548	AE548	AE548
4	Coupling Assembly	1	AE544F-1	AE544F-1	AE544B-1	AE544F-1	AE544B-1	AE544B-1	AE544F-1	AE544B-1	AE544B-1
5	Shroud Drive End	1	AN186	AN186	AN186	AN186	AN186	AN186	AN186	AN186	AN186
6	Fan	2	AK735	AK735	AK735	AK735	AK735	AK735	AK735	AK735	AK735
7	Baffle	2	AN187	AN187	AN187	AN187	AN187	AN187	AN187	AN187	AN187
8	End Cap	1	AB790	AB790	AB790	AB790	AB790	AB790	AB790	AB790	AB790
*9	Bearing	2	AB964J	AB964J	AB964J	AB964J	AB964J	AB964J	AB964J	AB964J	AB964J
10	Bearing Spacer	2	AB926T	AB926T	AB926T	AB926T	AB926T	AB926T	AB926T	AB926T	AB926T
11	Dead End Plate	1	AN113A	AN113A	AN113A	AN113A	AN113A	AN113A	AN113A	AN113A	AN113A
12	Body	1	AN104	AN105	AN106D	AN104	AN105	AN106	AN104A	AN105A	AN106A
13	Cover Plate	1/2	1-AN161	1-AN161	1-AN161	1-AN161	1-AN161	1-AN161	2-AN161	2-AN161	2-AN161
*14	Cover Plate Gasket	2	AN167	AN167	AN167	AN167	AN167	AN167	AN167	AN167	AN167
*15A	Filter	1	AN164	AN164	AN164	AN164	AN164	AN164	AN164	AN164	AN164
*15B	Muffler Element	1	AN165	AN165	AN165	AN165	AN165	AN165	AN165	AN165	AN165
*16	Filter Felt	1	----	----	----	----	----	----	AK335	AK335	AK335
*17	Muffler	1	----	----	----	----	----	----	AF353	AF353	AF353
*18	Vane	4	AN131	AN131	AN131	AN131	AN131	AN131	AN131	AN131	AN131
19	Rotor Assembly	1	AN130	AN130	AN130	AN130	AN130	AN130	AN130	AN130	AN130
20	Drive End Plate	1	AN113	AN113	AN113	AN113	AN113	AN113	AN113	AN113	AN113
21	Belleville Spring	2	AB791	AB791	AB791	AB791	AB791	AB791	AB791	AB791	AB791
22	Washer	1	AB792	AB792	AB792	AB792	AB792	AB792	AB792	AB792	AB792
23	Retainer Ring	1	AB793	AB793	AB793	AB793	AB793	AB793	AB793	AB793	AB793
24	Shroud, Dead End	1	AN185	AN185	AN185	AN185	AN185	AN185	AN185	AN185	AN185
*25	Foam	1	----	----	----	----	----	----	AN169	AN169	AN169
*26	Foam	1	----	----	----	----	----	----	AN170	AN170	AN170
27	Filter/Muffler Box	1	AN162	AN162	AN162	AN162	AN162	AN162	----	----	----
28	Cover	1	AN163	AN163	AN163	AN163A	AN163A	AN163A	----	----	----
*29	Gasket, Muffler Box	1	AN168	AN168	AN168	AN168	AN168	AN168	----	----	----
30	Tuning Tube	3	AN166A	AN166A	AN166A	----	----	----	----	----	----
31	Motor Shim	1	AN177	AN177	----	AN177	AN177	----	AN177	AN177	----
*	Repair Kit	1	K546	K546	K546	K546	K546	K546	K551	K551	K551
*	Filter/Muffler Kit	1	K552	K552	K552	K552	K552	K552	K547	K547	K547
ACCESSORIES											
	Vacuum Relief Valve	1	AN226	AN226	AN226	----	----	----	AN226	AN226	AN226
	Pressure Relief Valve	1	----	----	----	AN225	AN225	AN225	AN225	AN225	AN225
	Vacuum Gauge	1	AE136	AE136	AE136	----	----	----	AE136	AE136	AE136
	Pressure Gauge	1	----	----	----	AN190	AN190	AN190	AN190	AN190	AN190

Part numbers listed are for stock model units. For specific OEM models consult the factory.

Accessories listed are not shown in exploded view.

---- Not applicable

* Reflects parts included in the Repair Kit

* Reflects parts included in the Filter Replacement Kit

**ADJUSTABLE VACUUM/PRESSURE
RELIEF VALVE RECOMMENDATIONS**

Pressure Relief Valves		
PART #	SUGGESTED PRESSURE RANGE	SUGGESTED DUTY RANGE
AN225	1-15 lbs. per sq. in.	15-45 Cubic ft. per min.
AN225B	3-15 lbs. per sq. in.	45-75 Cubic ft. per min.
AN225A	.07-1.0 Bar	25-76 Cubic ft. per min.
AN225C	.2-1.0 Bar	76-127 Cubic ft. per min.

Vacuum Relief Valves		
AN226	5-25 in. of mercury	15-55 Cubic ft. per min.
AN226A	844-167 Millibar	25-93 Cubic meters per hr.

⚠ WARNING Relief Valves have set-screws (adhere in place using Loctite or similar product) to prevent cap from screwing entirely off. Do not remove. See above table for suggested operating range.

⚠ CAUTION Relief Valves have insulating, color coded sleeves (black for pressure, red for vacuum) to prevent the hand from contacting hot surfaces. Do not remove. The pressure relief valve will get particularly warm without the insulator while under pressure. Do not touch the lower portion of the valve.

Application of the relief valves may prevent a pump from hitting its maximum duty and will marginally reduce flow at a given duty as well due to the creation of an arbitrary leak path as the internal spring compresses slightly. ***Please do not mistake this for pump malfunction.***

Gast relief valves will withstand mild solvents. If solvent collects in valve, it will blow out during operation.

The customer needs to establish pressure requirements, then adjust appropriate regulator by turning the knob to required level.

