

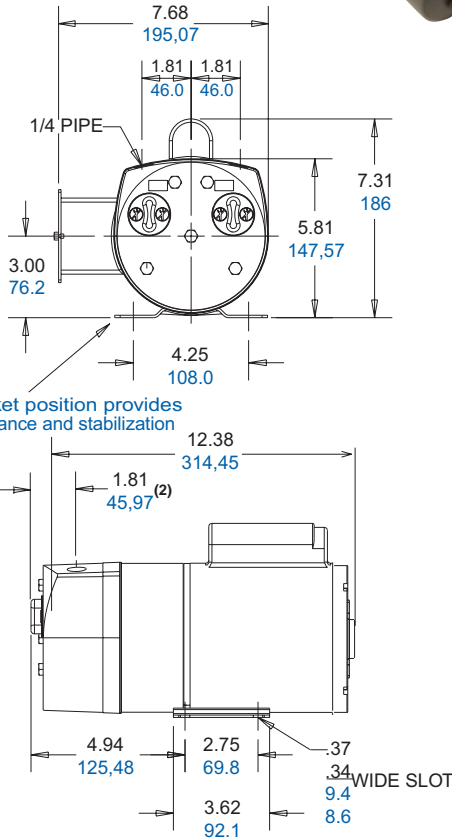

Product Dimensions (mm, inches)

Dimensions are for reference only.



Oilless RV Series RV03 and RV05 Models

MODEL RV03 SERIES

15" HG MAX. VAC., 3.8 CFM OPEN FLOW
5 PSI MAX. PRESSURE, 3.8 CFM OPEN FLOW

MODEL RV05 SERIES

10" HG MAX. VAC., 4.8 CFM OPEN FLOW
5 PSI MAX. PRESSURE, 4.8 CFM OPEN FLOW

PRODUCT FEATURES

- Oilless operation
- Motor mounted
- New motor design
 - non ventilated motor offers better protection from dirt, bugs and fire ants
 - rear motor fan for additional cooling
- Up to 20% reduction in power consumption
- Up to 5dB(A) sound improvement
- Less vibration
- Improved mounting stability
- UL Recognized pressure only

INCLUDES

- Thermotector (on Single Phase Units only)
- Internal muffler and filter
- Silencer B343B
- Foot support assembly AC136

RECOMMENDED ACCESSORIES

- Vacuum relief valve AA840A (0523/0823/1023/1423)
- Pressure relief valve AA600
- Vacuum gauge AA640
- Repair kit K882

Product Specifications

Model Number	Motor	RPM		HP	kW	Thermotector	Foot Assy.	Net Wt.	
		60 cycle	50 cycle					lbs.	kg
RV03-101-G650DAX	115/60-1	1725	-	1/6	0,12	•	•	31	14,0
RV05-101-G650DAX	115/60-1	1725	-	1/6	0,12	•	•	30	13,5

Product Performance (Metric, U.S.)

Gast Mfg. Inc
Post Office Box 97
Benton Harbor, MI. 49023-0097
Ph: 269/926-6171
Fax: 269/925-8288
www.gastmfg.com

Gast Manufacturing Inc., A Unit of IDEX Corporation, Benton Harbor, MI USA
• ph 269-926-6171 • fx 269-925-8288 • www.gastmfg.com ©Registered Trademark/™Trademark of Gast Manufacturing Inc., Copyright ©2004 Gast Manufacturing Inc. All rights reserved.

