

**Vacuum Pump**



**Compressor**

## Oiless 1550 Series

### MODEL 1550 SERIES

20" HG MAX. VAC., 14.5 CFM OPEN FLOW  
15 PSI MAX. PRESSURE

#### PRODUCT FEATURES

- Oilless operation
- Pulley driven (multiple speeds possible)
- Rugged construction/low maintenance
- Essentially pulse-free service

#### INCLUDES (on Standard Models)

- Filter AB600F (Vacuum Pump)/AC433 (Compressor)
- Muffler AB600J (Vacuum Pump)
- Cooling fan AC326C
- 5" P.D. pulley AB140

#### RECOMMENDED ACCESSORIES

- Base AB897A (Vacuum Pump)/AB889A (Compressor)
- Belt guard AB332B (Vacuum Pump)
- Belt guard AB334B (Compressor)
- Vacuum relief valve AA840A
- Pressure relief valve AA600
- Vacuum gauge AA640
- Pressure gauge AA644B
- Repair kit K231A

#### Product Dimensions (mm, inches)

Dimensions are for reference only.

#### Vacuum Pump

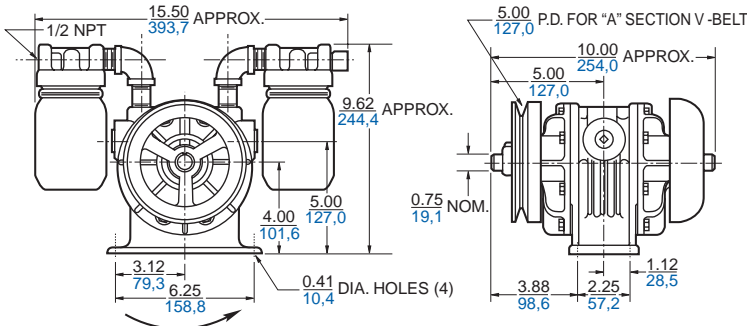

#### Compressor

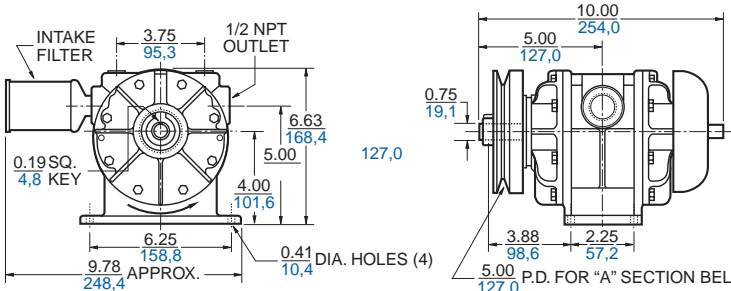

#### Product Performance (Metric, U.S.)

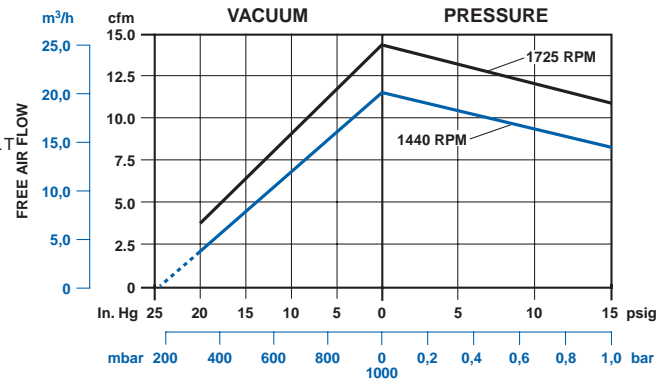

#### Product Specifications

Note: "P" models are pressure, "V" models are vacuum.

Model Number	Motor	Belt Guard	Base	Thermotector	RPM	HP	kW	Net Wt.	
								lbs.	kg
1550-P139B	—	—	—	—	1440	1	0,75	30	13,5
1550-P140J	—	•	•	—	1725	1½	1,1	57	25,7
1550-141J-T336 (P)	230/460-60-3	•	•	—	1725	1½	1,1	89	40,1
1550-P139B-SD110-1*	220/240-380/415-50-3 IP54	•	•	—	1725	1½	1,1	89	40,1
1550-V136B	—	—	—	—	1725	¾	0,56	33	14,9
1550-V137J	—	•	•	—	1440	½	0,37	52	23,4
1550-V138K-G34AX	115/230-60-1	•	•	•	1440	½	0,37	76	34,2
1550-V137K	—	•	•	—	1725	¾	0,56	52	23,4
1550-V136B-SD100-1*	380/415-50-3	•	•	—	1725	1	0,75	80	36,0

\*Available only in Europe.