



## 81R Series Twin Cylinder Compressor

### MODEL 81R640

100 PSI MAX. PRESSURE, 3.7 CFM OPEN FLOW (60 Hz)

100 PSI MAX. PRESSURE, 3.0 CFM OPEN FLOW (50 Hz)

#### PRODUCT FEATURES

- Oilless operation
- All wetted aluminum parts treated for corrosion protection from moisture
- Rugged motor shell construction

#### RECOMMENDED ACCESSORIES

- Safety valve AP202
- Pressure gauge AA806
- Filter B300A
- Repair kit K934
- Capacitor not included in unit - order separately AF485A (H311CX motor) AT251B (H302CX motor)

#### Product Dimensions (inches/mm)

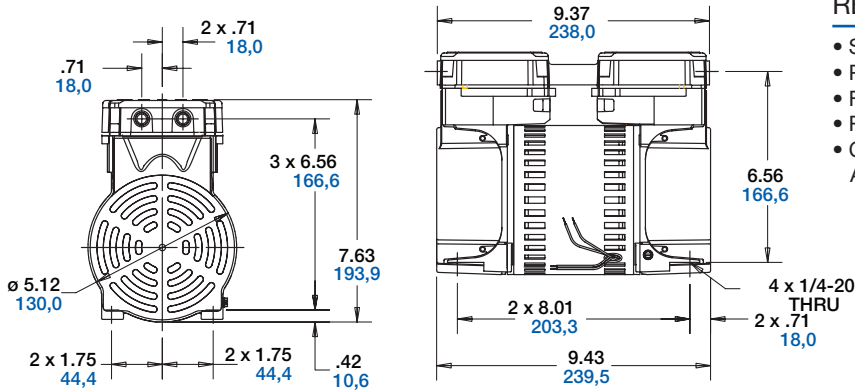

#### Product Specifications "P" models are pressure

Model Number	Motor	Motor Type	RPM		HP	kW	Wt	
			60 Hz	50 Hz			lbs.	kg+
+81R640-P101-H311CX	115-60-1	PSC	1725		1/3	0,25	17.1	7,8
+81R640-P101-H302CX	220-240-50-1	PSC		1450	1/3	0,25	17.6	8.0

+Capacitor not included - order separately

#### Product Performance (U.S./Imperial, Metric)

