



Oilless Rocking Piston 2.0 cfm



71R Series Twin Cylinder Compressor High Pressure

MODEL 71R545 (TWO STAGE) 175 PSI MAX. PRESSURE, 2.0 CFM OPEN FLOW

PRODUCT FEATURES

- Oilless operation
- All wetted aluminum parts treated for corrosion protection from moisture
- Rugged motor shell construction

INCLUDES

- Capacitor AK385 (D401X Motor), AF485 (D302X Motor), attached
- Rubber feet (4) AB319
- Safety valve AT471
- Interstage filter AT441
- Filter B300F (not pictured, shipped unattached)

COMMON MOTOR OPTIONS

- 100/100-115V, 50/60 Hz, single phase
- 220/240V, 50 Hz, single phase

RECOMMENDED ACCESSORIES

- Pressure gauge

(mm) (inches)

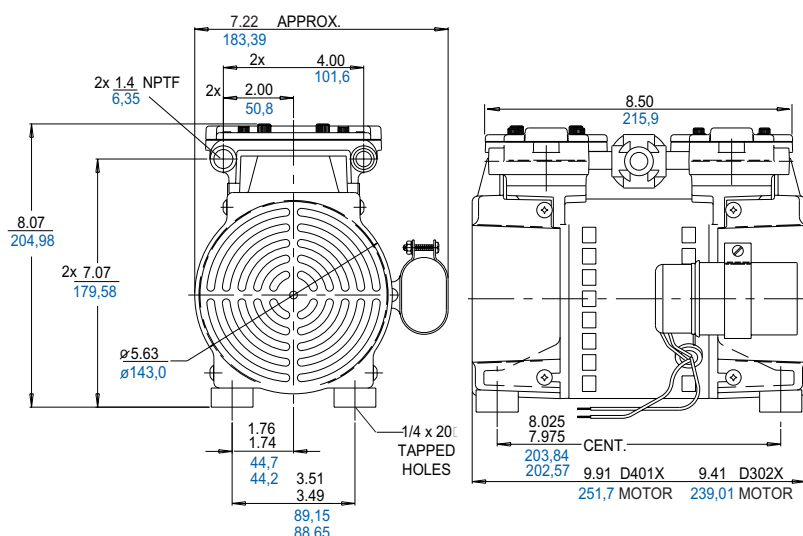

Product Specifications

Model Number	Motor	Type	RPM		HP	kw	Net Wt.	
			60 Cycle	50 Cycle			lbs.	kg
71R545-P315B-D401X	100/100-115-50/60-1	PSC (4 Pole)	1725	1425	1/2	0,37	15/6	7,09
71R545-P315B-D302X	220-240-50-1	PSC (4 Pole)	-	1425	1/3	0,25	16.0	7,27

Product Performance (Metric, U.S.)

