



71R Series Twin Cylinder High Pressure Compressor

MODEL 71R545 STAGED

175 PSI MAX. PRESSURE, 2.0 CFM OPEN FLOW (60HZ)

PRODUCT FEATURES

- Oilless operation
- All wetted aluminum parts treated for corrosion protection from moisture
- Rugged motor shell construction

INCLUDES

- Capacitor AK385
- Rubber feet (4) AF713A
- Safety valve AS100J
- Interstage filter AT441
- Filter B300F not pictured, shipped unattached

RECOMMENDED ACCESSORIES

- Repair kit K634

Product Dimensions (Inches, mm).

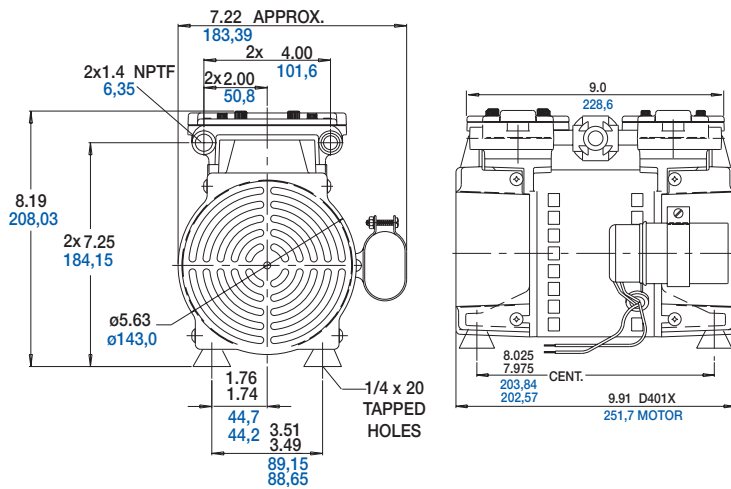

Product Specifications

Model Number	Motor	Motor Type	RPM		HP	kW	Wt	
			60 Hz	50 Hz			lbs.	kg
•71R545-P315B-D401X	100/115-60-1	PSC (4 pole)	1725	1425	1/2	0,37	15.6	7.09

•Unit shipped with capacitor

Product Performance (U.S./ Imperial, Metric)

