



## R3-R7 SERIES - EXPLOSION PROOF MOTORS



R3105N-50



R4 - R7 Series

MODELS	Maximum Pressure ("H <sub>2</sub> O)		Maximum Vacuum ("H <sub>2</sub> O)		Maximum Air Flow (CFM)	
	60 Hz	50 Hz	60 Hz	50 Hz	60 Hz	50 Hz
R3105N-50	43	31	40	28	53	44
R4110N-50 R4310P-50	51	38	48	35	92	74
R4P115N-50	65	45	60	40	133	112
R5125Q-50 R5325R-50	55 65	- 50	60 65	- 47	160 160	- 133
R6130Q-50 R6340R-50	60 100	75 75	70 80	65 65	215 215	180 180
R6P155Q-50 R6P355R-50	95 100	80 80	85 85	65 65	280 280	235 232
R7100R-50	100	90	110	85	425	350

### PRODUCT FEATURES

- Rugged design, maintenance free
- Quiet operation within OSHA standards
- Blowers and motors rated for continuous duty
- UL and CSA approved multi-voltage motors, incorporating approved thermal protection
- Motors classified as Explosion Proof Division 1 and 2, for Group D explosive atmospheres
- Motors carry full rated load at temperatures below Class B motor insulation limits
- Class F motor insulation used in motors larger than 1 HP
- Motors conform to NEMA frame sizes; motor enclosures conform to IP54 (suitable for outdoor use)
- Pilot duty thermal overload protection is standard on all 1 HP and larger motors
- Double sealed motor ball bearings with a B10 life exceeding 30,000 hours of continuous operation at the maximum rated continuous blower load
- Sealed air streams
- Aluminum impeller, housing and cover; viton shaft seal.
- Pressurized and leak-tested to less than 5cc/minute

Recommended Accessories	R3 Series	R4 Series	R4P Series	R5 Series	R6 Series	R6P Series	R7 Series
Pressure Gauge	AJ496	AJ496	AE133	AE133	AE133	AE133	AE133
Vacuum Gauge	AJ497	AJ497	AE134	AE134	AE134	AE134	AE134
Pressure Filter	AJ126C	AJ126D	AJ126D	AJ126D	AJ126F	AJ126F	AJ126G
Vacuum Filter (Inline)	AJ151C	AJ151D	AJ151D	AJ151E	AJ151G	AJ151G	AJ151H



## Product Dimensions (in. mm)

### Model R3

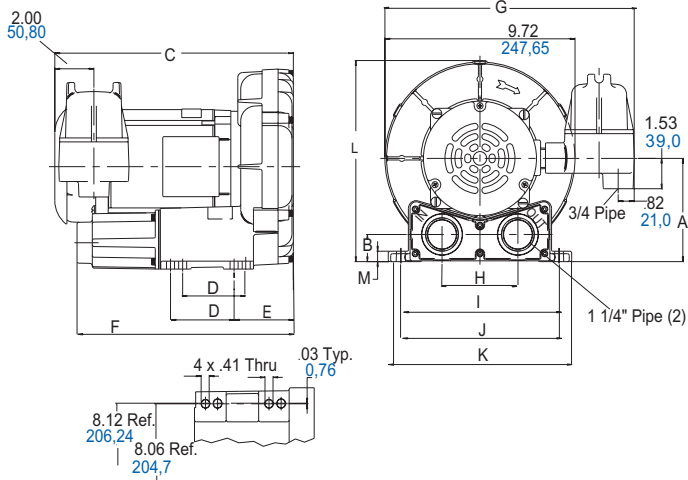

### Models R6P, R7

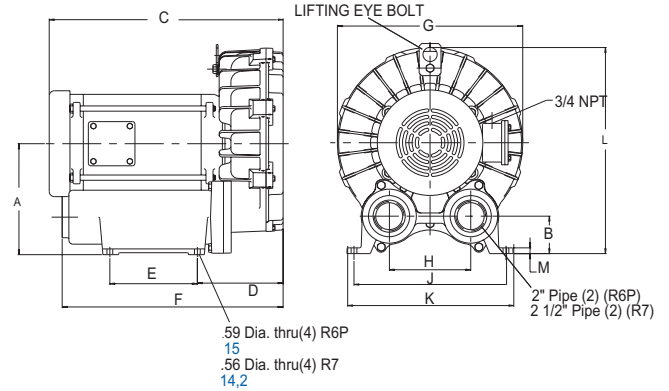

### Models R4, R4P, R5, R6

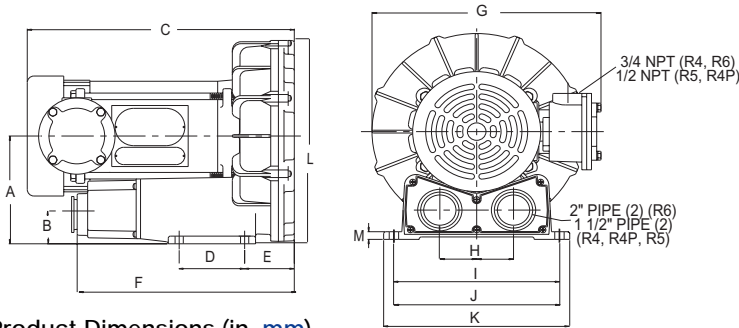

### Mounting Hole Detail

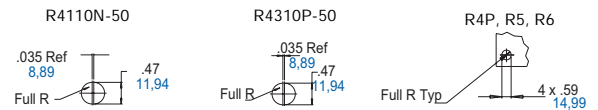

## Product Dimensions (in. mm)

Model	A	B	C	D	E	F	G	H	I	J	K	L	M
<b>R3105N-50</b>	5.21 132	1.37 35	12.3 312	3.25 83	3.06 78	11.06 281	12.75 324	3.88 99	8.06 205	8.12 206	9.38 238	10.15 258	.53 13
<b>R4110N-50</b>	6.18 157	1.68 43	15.34 390	3.75 95	2.85 72	12.44 316	12.34 313	3.96 101	8.86 225	8.93 227	10.00 254	11.80 300	.44 11
<b>R4310P-50</b>	6.18 157	1.68 43	14.09 358	3.75 95	2.84 74	12.44 316	12.34 313	3.96 101	8.86 225	8.93 227	10.00 254	11.80 300	.44 11
<b>R4P115N-50</b>	6.98 177	1.84 47	17.41 442	4.50 114	3.25 83	13.93 354	13.75 349	4.75 121	10.25 260	10.31 262	11.75 298	13.61 346	.60 15
<b>R5125Q-50</b>	7.02 178	1.82 46	17.59 447	4.50 114	3.55 90	14.22 361	13.72 348	4.75 121	10.25 260	10.31 262	11.75 298	13.80 351	.59 15
<b>R5325R-50</b>	7.02 178	1.82 46	16.75 425	4.50 114	3.55 90	14.22 361	13.56 344	4.75 121	10.25 260	10.31 262	11.75 298	13.80 351	.59 15
<b>R6130Q-50</b>	7.75 197	1.94 49	18.97 482	5.50 140	3.85 98	16.02 407	15.17 385	4.92 125	11.38 289	11.42 290	12.96 329	15.34 390	.52 13
<b>R6340R-50</b>	7.75 197	1.94 49	18.82 478	5.50 140	3.85 98	15.89 404	15.17 385	4.92 125	11.38 298	11.42 290	12.96 329	15.34 390	.52 13
<b>R6P155Q-50</b>	9.77 248	3.15 80	22.81 579	5.12 130	5.51 140	16.85 428	16.75 425	5.00 127	- -	11.42 290	12.80 325	18.14 461	.50 13
<b>R6P355R-50</b>	9.77 248	3.15 80	19.92 506	5.12 130	5.51 140	16.85 428	16.75 425	5.00 127	- -	11.42 290	12.80 325	18.14 461	.50 13
<b>R7100R-50</b>	10.79 274	3.64 92	22.77 578	8.36 212	8.50 216	21.50 546	18.00 457	7.90 201	- -	14.76 375	16.14 410	20.03 509	.56 14

Notice: Specifications subject to change without notice.



## Product Specifications

MODEL NUMBER		R3105N-50	R4110N-50	R4310P-50	R4P115N-50
Motor Enclosure		XPFC	XPFC	XPFC	XPFC
HP/kW	60 Hz	.50/0,37	1.0/0,75	1.0/0,75	1.5/1,1
	50 Hz	.33/0,25	.60/0,45	.60/0,45	1.0/0,75
Voltage	60 Hz	115/208-230-1	115/208-230-1	208-230/460-3	115/208-230-1
	50 Hz	110/220-240-1	110/220-240-1	220/380-3	110/220-240-1
Amps	60 Hz	5.2/2.9-2.6	11.4/6.2-5.6	3.4-3.3/1.6	20.3/11.2-10.6
	50 Hz	4.8/2.4-2.2	9.2/5.2-4.6	3.2/1.6	15.2/7.6-8
Starting Amps	60 Hz	12.5 @ 230V	36.5 @ 230V	19.7 @ 230V	60.6 @ 230V
	50 Hz	13 @ 220V	40.6 @ 240V	23.3 @ 220V	Consult Factory
Insulation Class		B	B	B	F
Recommended NEMA Starter Size		00/00	0/00	0/0	1/0
Net Weight (lbs/kg)		52/24	60/28	58/27	79/36

MODEL NUMBER		R5125Q-50	R5325R-50	R6130Q-50	R6340R-50
Motor Enclosure		XPFC	XPFC	XPFC	XPFC
HP/kW	60 Hz	2.0/1,5	2.0/1,5	3.0/2,2	4.0/3,0
	50 Hz	-	1.5/1,1	2.5/1,9	3.0/2,2
Voltage	60 Hz	115/230-1	208-230/460-3	230-1	208-230/460-3
	50 Hz	-	190-220/380-415-3	220-240-1	190-220/380-415-3
Amps	60 Hz	25/12.5	6.6-6.1/3.05	16.3	13-12/6
	50 Hz	-	5.0-4.4/2.5-2.6	14.7-13.5	14.4-13.4/7.2-6.8
Starting Amps	60 Hz	78 @ 230V	48 @ 230V	64 @ 230V	125 @ 230V
	50 Hz	-	Consult Factory	Consult Factory	Consult Factory
Insulation Class		F	F	F	F
Recommended NEMA Starter Size		1/0	0/0	1	1/0
Net Weight (lbs/kg)		77/35	75/34	129/59	112/51

MODEL NUMBER		R6P155Q-50	R6P355R-50	R7100R-50
Motor Enclosure		XPFC	XPFC	XPFC
HP/kW	60 Hz	5.5/4,1	6.0/4,5	10/7,5
	50 Hz	4.0/3,0	4.5/3,4	8.0/6,0
Voltage	60 Hz	230-1	208-230/460-3	208-230/460-3
	50 Hz	220-240-1	190-220/380-415-3	190-220/380-415-3
Amps	60 Hz	29.9	20-18/9	26.5-24/12
	50 Hz	20.8-19.1	14.9-11/7.45-5.8	23.2-21.0/11.6-10.9
Starting Amps	60 Hz	198.4 @ 230V	59 @ 460V	105 @ 460V
	50 Hz	189 @ 240V	Consult Factory	Consult Factory
Insulation Class		F	F	F
Recommended NEMA Starter Size		0/2	1/0	2/1
Net Weight (lbs/kg)		243/110	233/105	297/134



## R5325R-50

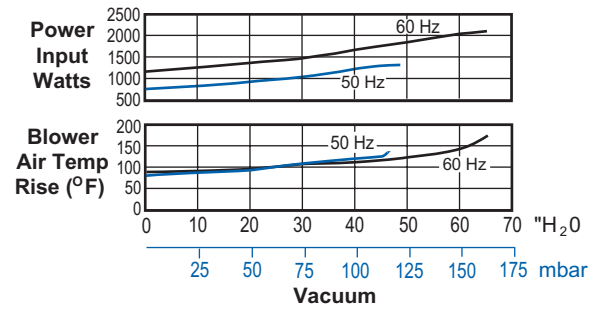
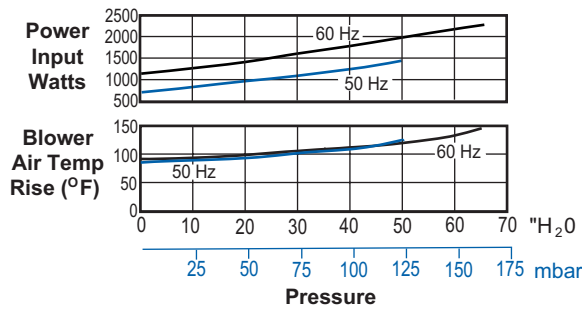
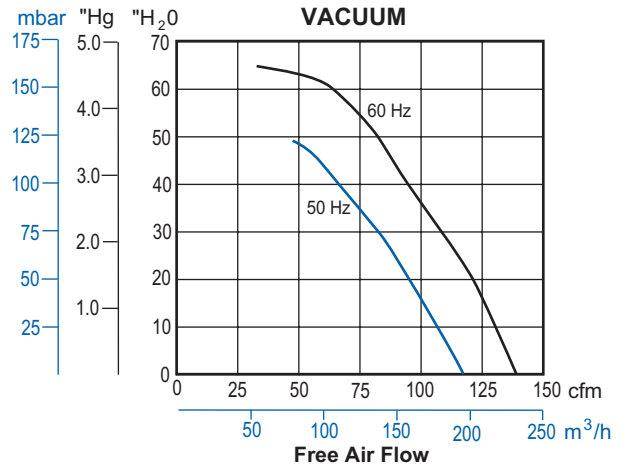
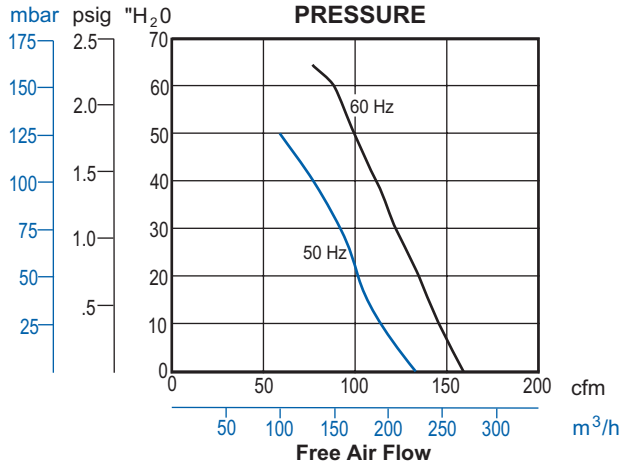

## R6130Q-50

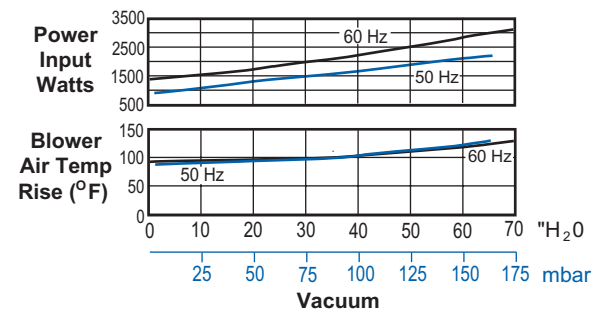
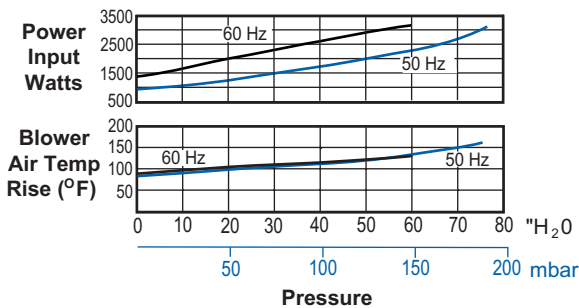
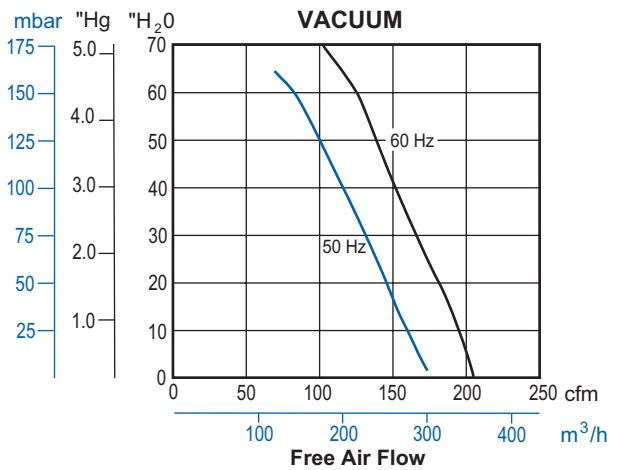
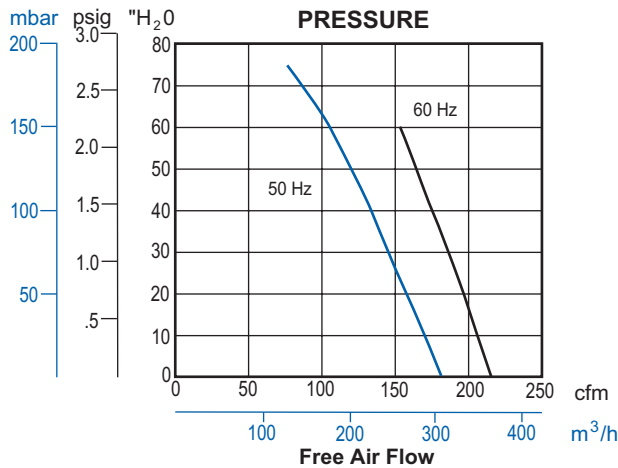



- Q. What happens to the noise when I locate two blowers close together?
- A. If the blowers are of the same design they produce sound frequencies that are close together. These may cause a “beating” change in volume of the blower noise. This is because the units are not synchronized. If two small blowers are needed this change in volume can be reduced by moving them further apart. With larger blowers a dual blower with two blowers on one motor will solve this problem.
- Q. What causes the noise relief valves make?
- A. Air rush through the valve.
- Q. How do I control relief valve or bleed off valve noise?
- A. Attach AJ121 series silencer on the port of the relief valve that is open to atmosphere.
- Contact Gast at 616-926-6171 or [www.gastmfg.com](http://www.gastmfg.com) with any further questions you may have on reducing blower noise in your application.

### Noise Reduction and Absorption Coefficients for Common and Specialty Noise Reduction Materials

	125Hz	250Hz	500Hz	1000Hz	2000Hz	4000Hz	NRC
Brick, unglazed	.03	.03	.03	.04	.05	.07	.04
Carpet							
1/4 in pile height	.05	.10	.15	.30	.50	.55	.26
Fabric							
Heavy Velour							
18 oz per sq. yd							
draped to 1/2 area	.14	.35	.55	.72	.70	.65	.62
Hardwood							
Plywood Paneling							
1/4 in thick							
wood frame	.58	.22	.07	.04	.03	.07	.09
Tecnifoam*							
TFP4							
Pyramid shape	.39	.60	1.21	1.14	1.16	1.13	1.05
Tecnifoam*							
TFW4000							
Anaechoic							
Wedge shape	.64	1.10	1.34	1.23	1.24	1.21	1.25

Source: Mechanical Engineering Reference Manual

\*TFP4 and TFW4000 are products of Tecnifoam, Inc., 7145 Boone Avenue North, Minneapolis, MN., 55428

## Blower Sound Levels of Gast Blowers

Data is highest sound level out of 4 places around the blower at 1 meter.

Data represents average of several units run at nominal voltage.

Lowest to highest maximum dba level throughout performance range is shown.

Readings at other than the maximum around the blower at 1 meter may be from 2 to 10 dba less than data shown.

Readings taken in a laboratory sound room that does not reflect much noise.

Note: For comparison purposes, some blower manufacturers show sound data from 1–1/2 meters instead of from 1 meter; also, some blower manufacturers show an “average” sound level across performance instead of the full range between minimum and maximum sound levels; either of these methods will provide different and usually lower sound levels compared to Gast’s sound level method.

60Hz	dBa at Pressure	50Hz	dBa at Pressure
R1	59-67	R1	59-64
R2	66	R2	61-63
R3	67-70	R3	63-68
R4	69-73	R4	64-69
R4P	69-75	R4P	64-71
R5	73-77	R5	71-77
R6	73-79	R6	70-79
R6P	82-83	R6P	77-80
R6PP	77-79	R6PP	73-76
R6PS	76-77	R6PS	72-75
R7	82-84	R7	77-79
R7P	77-80	R7P	74-79
R7S	75-77	R7S	72-76
R9	82-85	R9	78-85
R9P	81-88	R9P	79-86
R9S	79-81	R9S	77-81
R4H	80-82	R4H	75-81
R4M	82-83	R4M	78-79
R7H	83	R7H	79-81

60Hz	dBa at Vacuum	50Hz	dBa at Vacuum
R1	58-63	R1	54-60
R2	67	R2	63-64
R3	67-71	R3	64-69
R4	70-72	R4	66-70
R4P	73-74	R4P	68-71
R5	75-76	R5	71-73
R6	78-80	R6	74-77
R6P	81-85	R6P	79-81
R6PP	81-83	R6PP	78-79
R6PS	79-81	R6PS	76-77
R7	85-87	R7	79-84
R7P	84-86	R7P	80-83
R7S	82-83	R7S	78-80
R9	85-90	R9	83-84
R9P	88-90	R9P	84-87
R9S	87-88	R9S	83-86
R4H	82-89	R4H	79-88
R4M	85-89	R4M	80-85
R7H	82-91	R7H	80-90