



Medium Capacity Oilless Linear Pump to 120 lpm

F1-50/08-03



DDL30-DDL40 DDL60-DDL80 Series



MODELS DDL30

5.4 PSI MAX. PRESSURE (.37 bar) 54 LPM OPEN FLOW (60 Hz)
5.1 PSI MAX. PRESSURE (.35 bar) 65 LPM OPEN FLOW (50 Hz)

MODELS DDL40

5.9 PSI MAX. PRESSURE (.41 bar) 65 LPM OPEN FLOW (60 Hz)
5.8 PSI MAX. PRESSURE (.40 bar) 76 LPM OPEN FLOW (50 Hz)

MODELS DDL60

6.3 PSI MAX. PRESSURE (.43 bar) 79 LPM OPEN FLOW (60 Hz)
6.1 PSI MAX. PRESSURE (.42 bar) 102 LPM OPEN FLOW (50 Hz)

MODELS DDL80

7.0 PSI MAX. PRESSURE (.48 bar) 120 LPM OPEN FLOW (60 Hz)
7.0 PSI MAX. PRESSURE (.48 bar) 111 LPM OPEN FLOW (50 Hz)

Product Dimensions (mm, inches)

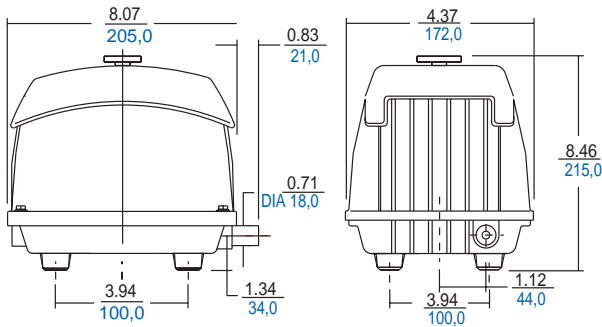

PRODUCT FEATURES

- All 101 models include a 6 ft. cord/plug assembly
 - 501 models include a 1.8 metre cord with pigtails
 - 801 models include a 1.8 metre cord with pigtails (not shown in photo or drawing)
- Additional plug configurations available
- CE In compliance with the European Community's Machinery Directive.
- UL listed aquarium equipment
- Quiet operation
- Drop into existing system
- Aluminum housing for better ventilation

Product Specifications

Model Number	Operating Voltage/ Frequency (Hz)	Max Power Watts	Sound Level dB(a)	Net Wt. lbs kg
DDL30-101	120-60	36	40	12 5.4
DDL30-501	230-60	36	40	12 5.4
DDL30-801	230-50	36	40	12 5.4
DDL40-101	120-60	47	41	12 5.4
DDL40-501	230-60	44	41	12 5.4
DDL40-801	230-50	44	38	12 5.4
DDL60-101	120-60	63	50	13 6.3
DDL60-501	230-60	53	50	13 6.3
DDL60-801	230-50	53	40	13 6.3
DDL80-101	120-60	93	52	13 6.3
DDL80-501	230-60	79	52	13 6.3
DDL80-801	230-50	79	40	13 6.3

Product Performance (Metric, U.S.)

