

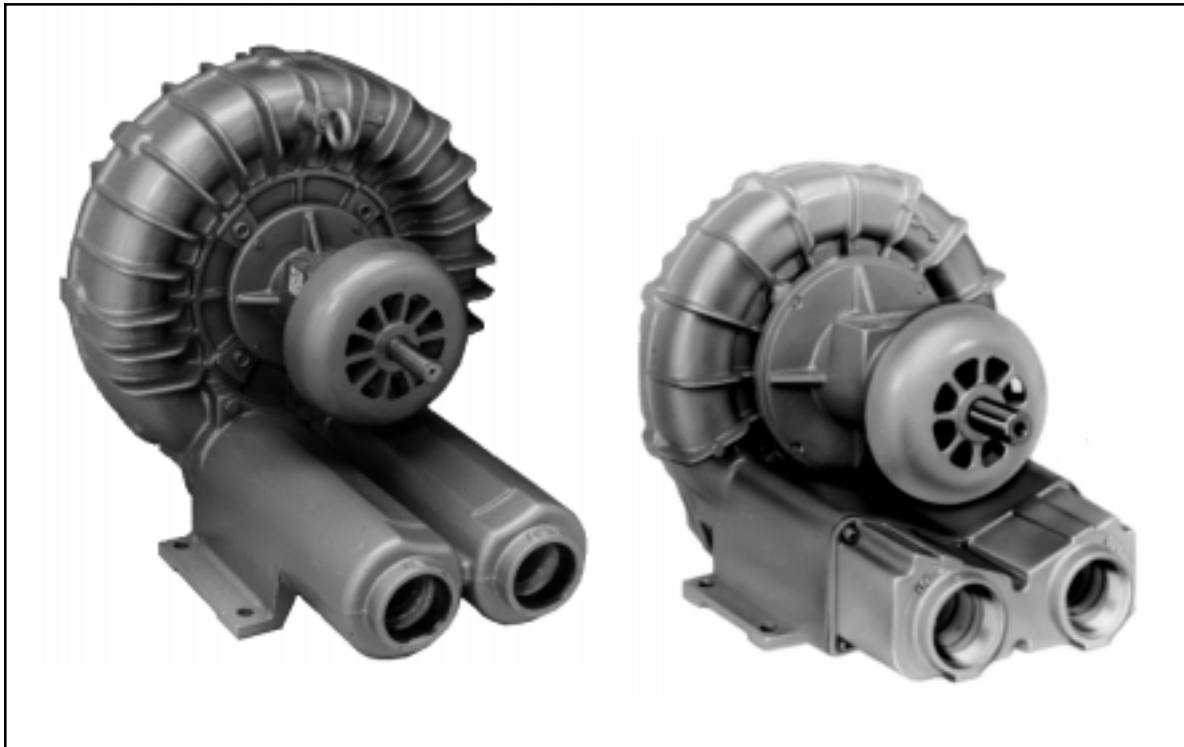

# SEPARATE DRIVE REGENAIR BLOWER

## OPERATION AND MAINTENANCE TECHNICAL MANUAL



### CONTENTS:

General Information, and Installation .....	2
Operation, Maintenance and Inspection.....	3
Belt Tensioning & Alignment .....	4
Exploded View and Parts Ordering Information.....	5
Troubleshooting and Accessories.....	6-7
Service Facilities.....	8

KEEP THIS DOCUMENT FOR FUTURE REFERENCE

This is the hazard alert symbol: ⚠ When you see this symbol, be aware that personal injury or property damage is possible. The hazard is explained in the text following the symbol. Read the information carefully before proceeding.

The following is an explanation of the three different types of hazards:

- ⚠ **DANGER** Severe personal injury or death will occur if hazard is ignored.
- ⚠ **WARNING** Severe personal injury or death can occur if hazard is ignored.
- ⚠ **CAUTION** Minor injury or property damage can occur if hazard is ignored.

### GENERAL INFORMATION

This blower is only to be used for the purpose of pumping air and under no circumstances be used with any other gases. The blower must not be used for the pumping of fluids, particles, solids or any substances likely to cause fire or explosion.

- ⚠ **DANGER** Do not pump flammable or explosive gases or operate the unit in an atmosphere containing them. Severe personal injury will occur if hazard is ignored.
- ⚠ **WARNING** Keep hands or other body parts away from blower suction. Failure to do so could result in personal injury.
- ⚠ **CAUTION** The exhaust air of this blower can become hot. Do not direct exhaust air towards property that is temperature sensitive.
- ⚠ **CAUTION** Blowers may generate heat. To prevent burns, do not touch blower during operation or until unit has cooled.
- ⚠ **CAUTION** Required ambient temperature for normal operation should not exceed 40C (104 °F). Failure to do so could result in fire or property damage. For operation at higher temperatures, consult the factory.

Performance is reduced by lower atmospheric pressure found at high altitudes. Consult a Gast distributor for details.

Never lubricate this oil-less blower. The sealed bearings are grease-packed. Most of the components are made of corrosion resistant material and with proper filtration, the unit should last for years.

### INSTALLATION

**IMPORTANT:** Remove any plastic caps before starting blower. Any foreign material (burrs, chips, welding drops, slag, pipe cuttings, excess sealants, sand, lime, etc.) must be removed or filtered out. Any such material, no matter how small, that enters the blower can damage it. Clean out new plumbing before attaching to inlet.

- ⚠ **WARNING** Foreign material exiting the blower or plumbing can cause serious personal and/or property damage.
- ⚠ **WARNING** Beware of any exposed movable parts. Proper guards should be in place to prevent severe personal injury or death.
- ⚠ **WARNING** To avoid risk of electrocution do not use this product in an area where it could come in contact with water or other liquids. If exposed to the elements it must be weather protected.
- ⚠ **CAUTION** Do not block the flow of cooling air over the unit in any way.

Air contaminated with solid particles and/or liquid must be filtered out before entering the Regenerative Blower (see your local distributor or contact the factory for recommendations). All blowers should have mufflers, filters and all plumbing attached before starting.

### MOUNTING

- ⚠ **WARNING** Make sure the electric motor is properly grounded and the wiring is done by a qualified electrician familiar with NEMA-MG2 safety standards, the National Electric Code and all local safety codes.
- ⚠ **CAUTION** Attach blower to solid surface before starting, to prevent injury or damage from unit movement.

To reduce noise & vibration, the unit should be mounted to a stable, rigid operating surface that will not increase sound. If needed, inlet or discharge noise can be reduced by attaching muffler assemblies.

## ROTATION

The blower should only rotate clockwise as viewed from the drive shaft end of the blower. This is marked with an arrow on the casting. Proper rotation can be confirmed by checking air flow at the IN and OUT ports. On blowers powered by a 3 phase motor, rotation can be reversed by changing any two of the power lines.

## PLUMBING

To prevent air flow restriction and overheating the blower, use pipe and fittings that are the same size or larger than the threaded ports of the unit. The threaded pipe ports are designed as connection ports only and will not support the plumbing. This is especially important with the higher air flow rates associated with driving the blower in excess of 3,500 RPM. The ports are marked "IN" and "OUT". When installing the plumbing, be sure to use a small amount of pipe thread lubricant. This protects the threads in the aluminum housing. Dirt and chips, often found in new plumbing, should not be allowed to enter the blower. Install relief valves and gauges at the inlet or outlet, or both, to monitor performance. Check valves may be required to prevent back-streaming through the pump.

---

## OPERATION

- ⚠WARNING** Solid or liquid material exiting the unit can cause eye or skin damage. Keep away from air stream.
- ⚠WARNING** Beware when in close proximity to the port openings while the blower is in operation. The high speed impeller could cause serious personal injury.
- ⚠WARNING** Do not operate blower with inlet or exhaust plumbing removed as it protects the body from the high speed impeller.
- ⚠CAUTION** Do not operate units above recommended pressures or vacuum duties. To do so will damage the unit.
- ⚠WARNING** Some of these models may exceed 85 dB(A). When in close proximity to these models hearing protection is required. See Technical Data Sheet (if provided), for specific model(s). Higher blower operating speeds and pressures result in higher noise levels.

Fit correct sized pipes and choose accessories that reduce to a minimum air friction load loss. Do not throttle discharge or suction pipe to reduce capacity. Throttling increases differential pressure, which consequently increases power absorption and working temperature. When the blower is ran at duties above 125mbar (50" H<sub>2</sub>O) metal pipe may be required for the hot exhaust air.

**⚠CAUTION** Air temperature increases when passing through the blower. Outlet piping can cause burns. Access to these hot temperature areas should be guarded, limited, or marked "DANGER HOT".

Once the blower is in operation, check the following:

- Working pressure and vacuum values.
- Relief valve pressure or vacuum setting, adjust if needed.
- Measure motor current and compare with motor name plate data.
- Rated electrical overload cut-out.
- Check the ambient and discharge air temperatures to be sure they do not exceed allowed values one hour after starting.

---

## MAINTENANCE & INSPECTION

**⚠WARNING** Power must be de-energized and disconnected before servicing. Be sure all rotating parts have stopped. Electric shock or severe cuts can result if hazard is ignored.

The noise absorbing foam used in mufflers needs to be periodically replaced. The electric motor and blower also need periodic cleaning to remove accumulated dust & dirt. If they are not cleaned, this can result in excessive vibration, an increase in temperature, or can reduce the service life of the system.

**Maintenance & Inspection (cont.)**

An increase in the differential pressure across an inlet filter indicates its getting clogged. Clean the inlet air filter as often as needed, blowing down against the current to clean it. Change the cartridge when cleaning no longer gets the cartridge clean. A dirty filter cartridge causes a high intake resistance resulting in an increase of differential pressure, absorbed power, and working temperature. Failure to clean or replace these filters will result in excessive pressure drop, a reduction in system air flow, and the blower will run hotter.

**BELT TENSIONING & ALIGNMENT**

Fig. 1 shows how a straight edge tool should be used to avoid Parallel or Angular misalignment. Table 1 shows the force needed on the electric motor shaft to properly tension the belt drive when the belt is installed. This table also shows the small force needed to cause 1/4" of deflection in the belt, see Fig. 2. This is used to check belt tension in new drives or those in service.

**⚠ CAUTION** Do not over tighten belt as it will cause misalignment and could lead to premature failure.

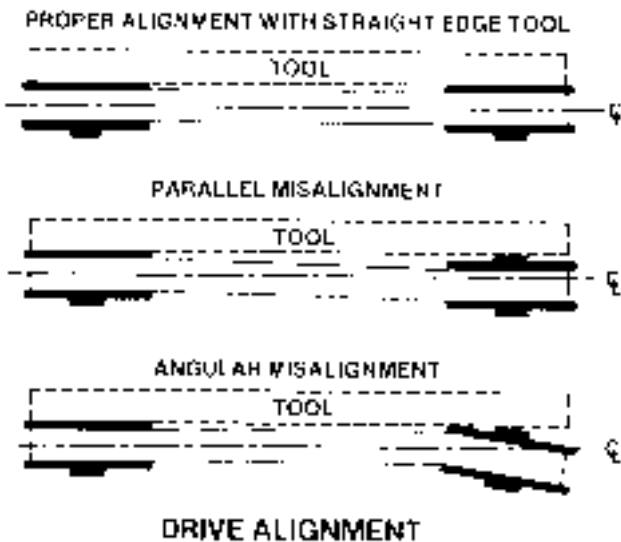
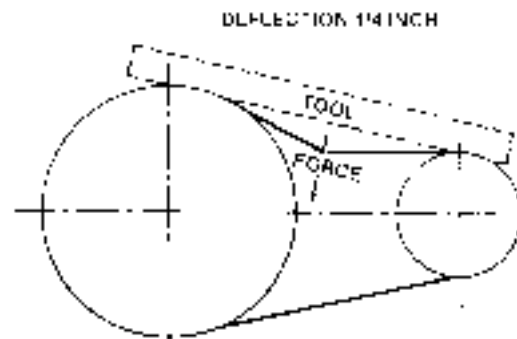

FIGURE 1

**Belt Tensioning & Alignment (cont.)**

We strongly suggest using the Gates Poly Chain Drive featured in our packaged belt drive blower. It has been properly engineered and the belt properly tensioned by the factory to insure long trouble free life of the blower.

If you choose to use a "V" belt drive the sheave on the blower must be less than 4" in outside diameter. This sheave should be mounted on the shaft such that it will not block air from entering the blower cooling fan. [ We recommend this high speed belt drive be engineered following the belt drive manufacturers recommendations.] To avoid annoying vibration and noise both sheaves should be dynamically balanced and fit snugly on the shaft.



CHECKING BELT TENSION WITH DEFLECTIO

FIGURE 2

**Gates "Poly Chain" Belt Tensioning Requirements**

Gast part# of complete Blower Assembly with Motor	Required pull on motor shaft for correct installation	Force to deflect belt 1/4" with new belt drive/Low limit for broken-in drive
SDR4-54-JT500	66 lb	3.5 / 3.0 lb
SDR4-50-JT300	66 lb	3.5 / 2.8 lb
SDR4-45-JT300	66 lb	3.5 / 2.5 lb
SDR5-54-JT1000	140 lb	7.5 / 6.0 lb
SDR5-52-JT1000	140 lb	7.5 / 5.5 lb
SDR5-48-JT750	100 lb	7.5 / 5.0 lb
SDR5-43-JT500	100 lb	7.5 / 4.5 lb
SDR5-41-JT500	100 lb	7.5 / 4.0 lb
SDR6-44-JT1000	160 lb	8.3 / 6.7 lb
SDR6-42-JT750	140 lb	7.5 / 6.0 lb
SDR6-40-JT750	140 lb	7.5 / 6.0 lb
SDR6-38-JT750	140 lb	7.5 / 5.5 lb

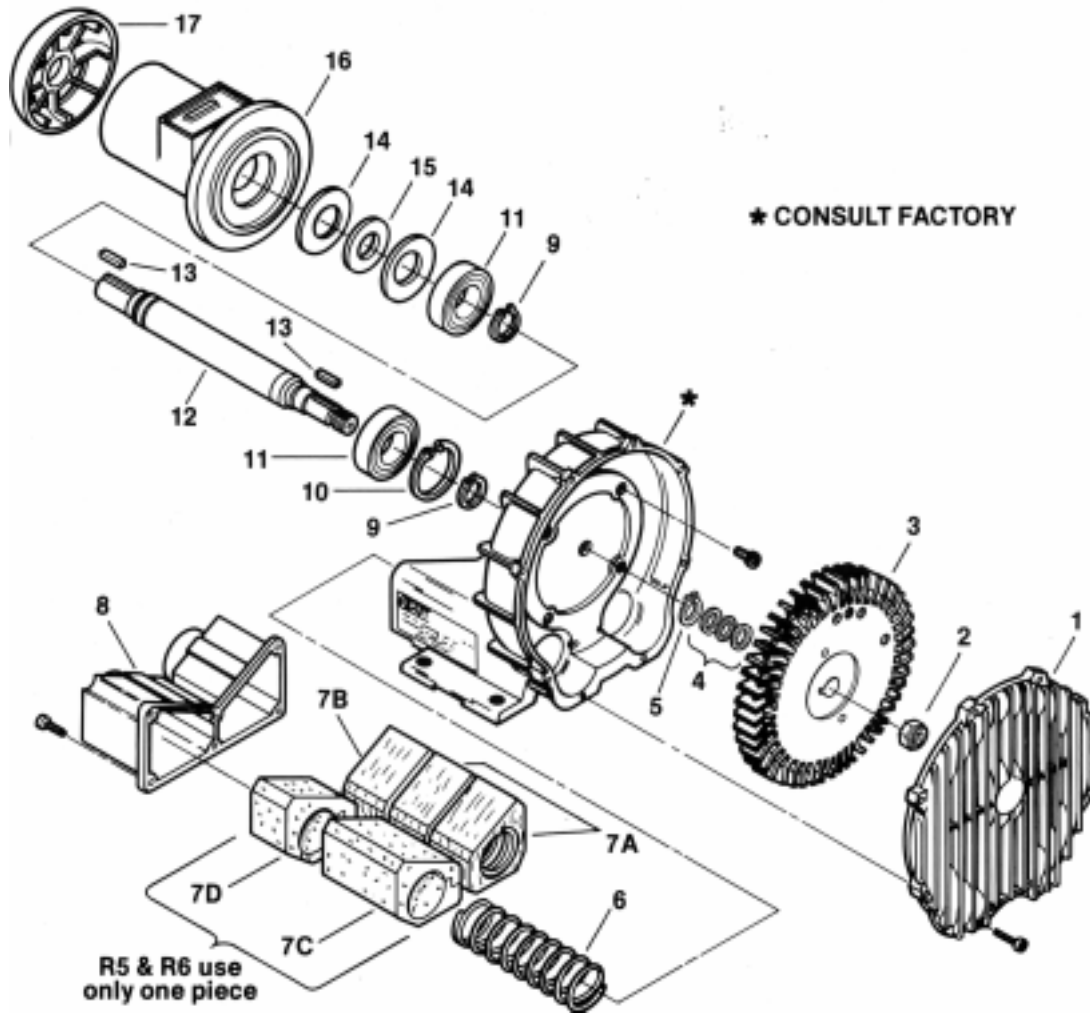

### PARTS ORDERING INFORMATION

Ref. No.	Description	Part Qty	SDR4	SDR5	SDR6	SDR6P
1	Cover	1	AJ101D	AJ101EQ	AJ101FB	AJ101K
2	Locknut	1	BC181	BC181	BC181	BC182
3	Impeller	1	AJ102D	AJ102E	AJ102FR	AJ102KA
4	Shim Spacers	As Req.	AJ109	AJ109	AJ109	AJ169 AJ169A
5	Retaining Ring	1	AJ149			
*	Housing	1	*	*	*	*
6	Spring	2	AJ113DR	AJ113DQ	AJ113FQ	AJ113FQ
7A	Inlet Foam	As Req.	(1) AJ112DR	(2) AJ112ER	(3) AJ112FC	(4) AJ112K
7B	Inlet Foam	As Req.	(2) AJ112DS	(1) AJ112EQ		
7C	Exhaust Foam	1	AJ112DA	(1) AJ112EA	(1)AJ112FD	(2) AJ112KA
7D	Exhaust Foam	1	AJ112DB			
8	Muffler Extension	1	AJ106DQ	AJ106EQ	AJ106FR	AJ104K
9	Retaining Ring	2	(2) AG900	(2) AG900	(2) AG900	(1) AG900
10	Big Ret. Ring	1	AB793	AB793	AB793	AB793
11	Bearing	2	(2) AB964J	(2) AB964J	(2) AB964J	(1) AB964J (1) AJ168
12	Shaft	1	AJ157	AJ154	AJ154	AJ164
13	Key	2	(1)AB136 (1)AB136D	AB136	AB136	AB136
14	Bearing Spring	2	AB791	AB791	AB791	AB791
15	Washer	1	AB792	AB792	AB792	AB792
16	Remote Drive Housing	1	AJ153	AJ153	AJ153	AJ153
17	Fan	1	AD235D	AD236B	AD236B	AD236B

TROUBLESHOOTING GUIDE		
SYMPTOM	POSSIBLE DIAGNOSIS	POSSIBLE REMEDY
Unusual belt noise	•misaligned drive •too high or low belt tension	•correct alignment •adjust tension to correct value
Loss of belt tension	•motor or blower not bolted down tightly •debris being pinched in between belt & sprocket	•check for loose bolts then realign and tension •keep Gast supplied belt guard in place
Excessive wear to edge of belt	•misaligned drive	•correct alignment
Premature wear or shearing of belt	•too high or low belt tension •blower jammed	•Adjust tension to correct value check to teeth •check the blower, will it turn easily
Broken belt	•debris being pinched in between belt & sprocket	•keep Gast supplied belt guard in place
Excessive vibration	•loose sprocket or key •Impeller damaged by foreign material •Impeller contaminated by foreign material	•tighten and/or use Loctite to prevent movement •replace impeller •clean impeller, install adequate filtration
Abnormal Sound	•Impeller damaged or contaminated by foreign material	•Replace or clean Impeller •Install adequate filtration
Increase in Sound	•Foreign material or heat can destroy muffler foam	•Replace foam muffler elements, filter foreign material
Blown Fuse	•Electrical wiring problem	•Have qualified person check that impeller turns •check fuse, wiring diagram, or wiring capacity
Unit very hot	•Running at too high a pressure or vacuum	•Install a relief valve and pressure or vacuum gauge

## Accessories for GAST REGENAIR Blowers

### Relief Valve

By setting a relief valve at a given pressure/vacuum you can be assured that no harm will come to the blower or products in your application from excessive duties.

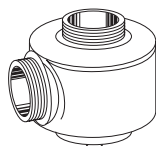

AG258

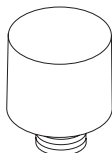

PV Series

- Pressure/Vacuum Relief Valve, 1<sup>1</sup>/<sub>2</sub>" NPT, Adjustable 30-170 in. H<sub>2</sub>O, 200 cfm max. **Part #AG258**
- Silencer for AG258 Relief Valve **Part #AJ121D**
- Pressure/Vacuum Relief Valve, 2<sup>1</sup>/<sub>2</sub>"NPT, Adjustable for higher flows. **Part #AG258F**
- Silencer for AG258F Relief Valve, **Part #AJ121G**
- Pressure Relief Valve, 1<sup>1</sup>/<sub>4</sub>" NPT, preset for 6.5 psi for 50 Hz, **Part #PV065**
- Pressure Relief Valve, 1<sup>1</sup>/<sub>4</sub>" NPT, preset for 7.2 psi, for 60 Hz, **Part #PV072**
- Pressure Relief Valve, 1<sup>1</sup>/<sub>4</sub>" NPT, preset for 8.4 psi, for 50 Hz, **Part #PV084**
- Pressure Relief Valve, 1<sup>1</sup>/<sub>4</sub>" NPT, preset for 9.1 psi, for 60 Hz, **Part #PV091**
- Pressure Relief Valve, 1<sup>1</sup>/<sub>4</sub>" NPT, preset for 9.8 psi, for 50 Hz, **Part #PV098**
- Pressure Relief Valve, 1<sup>1</sup>/<sub>4</sub>" NPT, preset for 10.2 psi, for 60 Hz, **Part #PV102**

### Pressure-Vacuum Gauge

To monitor the system performance so as not to exceed maximum duties. Using two (one on each side of the filter) is a great way to know when the filter needs servicing.



- Pressure Gauge, **Part# AJ496**, 2<sup>5</sup>/<sub>8</sub>" Dia., 1<sup>1</sup>/<sub>4</sub>" NPT, 0-60in. H<sub>2</sub>O and 0-150 mbar
- Pressure Gauge, **Part# AE133**, 2<sup>5</sup>/<sub>8</sub>" Dia., 1<sup>1</sup>/<sub>4</sub>" NPT, 0-160in. H<sub>2</sub>O and 0-400 mbar
- Pressure Gauge, **Part# AE133A**, 2<sup>5</sup>/<sub>8</sub>" Dia., 1<sup>1</sup>/<sub>4</sub>" NPT, 0-200in. H<sub>2</sub>O
- Vacuum Gauge, **Part# AJ497**, 2<sup>5</sup>/<sub>8</sub>" Dia., 1<sup>1</sup>/<sub>4</sub>" NPT, 0-60in. H<sub>2</sub>O and 0-150 mbar
- Vacuum Gauge, **Part# AE134**, 2<sup>5</sup>/<sub>8</sub>" Dia., 1<sup>1</sup>/<sub>4</sub>" NPT, 0-160 in. H<sub>2</sub>O and 0-400 mbar

## Moisture Separators (for vacuum)

The purpose of the moisture separator is to remove liquids from the gas stream in a vacuum process. This helps protect the blower from corrosion and a build up of mineral deposits.

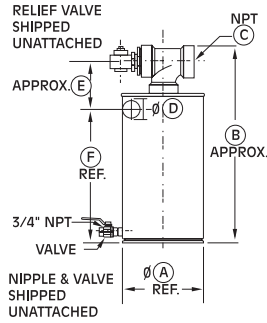

Model No.	R4, R4P, R5 R2M, R3M	R4, R4P, R5, R6, R6M	R5, R6, R6P, R6PS	R6P, R6PP, R7, R7S
Part No.	RMS160	RMS200	RMS300	RMS400
Liquid Cap (gal.)	10	19	19	40
A (dia.)	14.8"	19.7"	19.7"	24"
Dim. B	41.5"	39"	39"	48"
C (NPT)	2"	2"	2.5"	3"
D (dia.)	2"	2"	2.5"	3"
Dim. E	7.5"	7.5"	7.5"	9.7"
Dim. F	26.6"	26.6"	26.6"	29"

## Inline Filters (for vacuum)

The impeller of a blower passes very close to the housing. It is recommended to have an inlet or inline filter to ensure troublefree life.

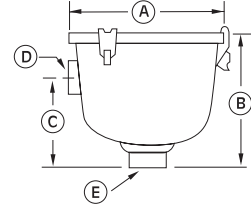

Model No.	R1	R2	R3, R1H	R4, R2H, R2M, R3M, R3H	SDR4, R4P, R5, R7H, R8H, R4H	SDR5, SDR6, R6, R6P, R9H, R5M, R6M, R7M	SDR6P, R6PP, R6PS, R7, R7S	R8M	R9M
Part No.	AJ151A	AJ151B	AJ151C	AJ151D	AJ151E	AJ151G	AJ151H	AJ151L	AJ151M
Dim. A	5.93"	7.38"	7.38"	7.38"	8.75"	8.00"	14.00"	14.00"	18.50"
Dim. B	4.50"	6.81"	6.81"	6.81"	10.25"	10.25"	26.50"	27.13"	28.13"
Dim. C	2.75"	4.62"	4.62"	4.62"	5.00"	5.50"	18.13"	18.5"	19.50"
Dim. D	1" FPT	1" FPT	1 1/4" FPT	1 1/2" FPT	2" FPT	2 1/2" FPT	3" MPT	4" MPT	5" MPT
Dim. E	1" FPT	1" FPT	1 1/4" FPT	1 1/2" FPT	2" FPT	2 1/2" FPT	3" MPT	4" MPT	5" MPT
Replacement Element	AJ135D	AJ135E	AJ135E	AJ135E	AJ135F	AJ135G	AJ135C	AJ135C	AJ135H
Micron	10	10	10	10	10	10	10	10	10

MPT = Male Pipe Thread      FPT = Female Pipe Thread

## Inlet Filters (for pressure)

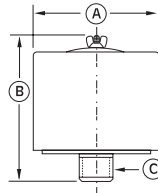

Model No.	R1 & R2	R3	R4, R5, SDR4, & R4P	SDR5, R6, SDR6, R6P, R6PP, R6PS	SDR6P, R7, R7P, R7S
Part No.	AJ126B	AJ126C	AJ126D	AJ126F	AJ126G
Dim. A	6.00"	6.00"	7.70"	10.63"	10.00"
Dim. B	4.62"	7.12"	7.25"	4.81"	13.12"
Dim. C	1" MPT	1 1/4" MPT	1 1/2" MPT	2" FPT	2 1/2" MPT
Replacement Element	AJ134B	AJ134C	AJ134E	AG340	AJ135A
Micron	10	10	10	10	10

MPT = Male Pipe Thread      FPT = Female Pipe Thread  
All are heavy-duty for high amount of particulates.  
Inlet filters for REGENAIR blowers are drip-proof when mounted as shown.

## Horizontal Swing Type Check Valve

Designed to prevent backwash of fluids that would enter the blower. Also prevents air backstreaming if needed. They can be mounted with their discharge either vertical or horizontal. Valve will open with 3" of water pressure.

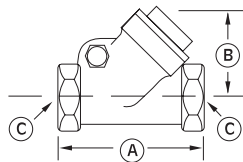

Model No.	R1 & R2	R3	R4, R5, SDR4, SDR5, R4P	R6, R6P, R6PS, SDR6, SDR6P	R7, R7S
Part No.	AH326B	AH326C	AH326D	AH326F	AH326G
Dim. A	3.57"	4.19"	4.50"	5.25"	8"
Dim. B	2.32"	2.69"	2.94"	3.82"	5.07"
Dim. C	1" NPT	1 1/4" NPT	1 1/2" NPT	2" NPT	2 1/2" NPT

## Mufflers

Designed to reduce noise by up to 5 dbA and remove high frequency sound associated with all blowers.

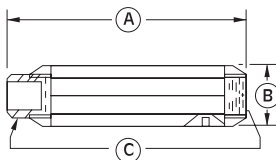

Model No.	R1 & R2	R3	R4, R5, SDR4, R4P	R6, SDR6P, SDR6, R6P, R6PP, R6PS	R7, R7P	R7S
Part No.	AJ121B	AJ121C	AJ121D	AJ121F	AJ121G	AJ121GE
Dim. A	7.46"	7.94"	12.75"	17.05"	17.44"	17.44"
Dim. B	2.38"	2.62"	3.25"	3.63"	4.25"	4.25"
Dim. C	1" NPT	1 1/4" NPT	1 1/2" NPT	2" NPT	2 1/2" NPT	2 1/2" NPT

## AUTHORIZED SERVICE FACILITIES

Gast Manufacturing Corp  
2300 Highway M-139  
Benton Harbor, MI 49023  
TEL: 616-926-6171  
FAX: 616-927-0808

Gast Manufacturing Corp  
505 Washington Ave  
Carlstadt, NJ 07072  
TEL: 201-933-8484  
FAX: 201-933-5545

Brenner Fiedler & Assoc.  
13824 Bentley Place  
Cerritos, CA 90701  
TEL: 800-843-5558  
TEL: 310-404-2721  
FAX: 310-404-7975

Gast Manufacturing Co., Ltd  
Beech House, Knaves Beech  
Business Centre, Loudwater  
High Wycombe, Bucks HP 10 9SD  
England  
TEL: 44 628 532600  
FAX: 44 628 532470

Wainbee Limited  
215 Brunswick Blvd.  
Pointe Claire, Quebec  
Canada H9R 4R7  
TEL: 514-697-8810  
FAX: 514-697-3070

Wainbee Limited  
5789 Coopers Avenue  
Mississauga, Ontario  
Canada L4Z 3S6  
TEL: 416-213-7202  
FAX: 416-213-7207

Japan Machinery Co. Ltd.  
Central PO Box 1451  
Tokyo, 100-91 Japan  
TEL: 81-3-3573-5421  
FAX: 81-3-3571-7865  
or: 81-3-3571-7896

NOTE: General Correspondence  
should be sent to--  
Gast Manufacturing Corp.  
P O Box 97  
Benton Harbor, MI 49023-0097

