

NL SERIES NON-LUBRICATED AIR MOTORS

OPERATION & MAINTENANCE MANUAL



Model NL22 Shown Model NL32 Shown

Thank you for purchasing this Gast product. It is manufactured to the highest standards using quality materials. **This manual includes general safety instructions for operation under normal conditions and for operation in hazardous conditions.** Please follow all recommended maintenance, operational and safety instructions and you will receive years of trouble free service.

WARNING



PLEASE READ THIS MANUAL COMPLETELY BEFORE INSTALLING AND USING THIS MOTOR. SAVE THIS MANUAL FOR FUTURE REFERENCE AND KEEP IN THE VICINITY OF THE MOTOR.

General information:

Operating Pressure: 80 psi or below (7 bar)

Product Use Criteria:

- Normal conditions: Operate at temperatures up to 250°F (121°C).
- Hazardous conditions: Operate at temperatures up to 104°F (40°C).
- Protect unit from dirt and moisture.
- Use **ONLY** compressed air to drive motor.
- Air lines connected to motor should be the same size or the next size larger than the inlet port for efficient output and speed control.
- Protect all surrounding items from exhaust air.
- Bearings are grease packed.
- Motors are to be used in commercial installations only.
-  **This symbol appears on labels of air motors that are designed for use in hazardous atmospheres. These air motors comply with the applicable standards and specifications and meet the requirements of the guidelines of the EC directive 94/9EC (ATEX 100a). They are intended to be used in zones 1 and 2 where explosive atmospheres are likely to occur.**
- Air supply, directional control valve and pressure regulator should be selected based upon the air consumption of the motor.



A Unit of **IBEX** Corporation

ISO 9001 & 14001 CERTIFIED

www.gastmfg.com

Your safety and the safety of others is extremely important.

We have provided many important safety messages in this manual and on your product. Always read and obey all safety messages.



This is the safety alert symbol. This symbol alerts you to hazards that can kill or hurt you and others. The safety alert symbol and the words “DANGER” and “WARNING” will precede all safety messages. These words mean:

DANGER

You will be killed or seriously injured if you don't follow instructions.

WARNING

You can be killed or seriously injured if you don't follow instructions.

All safety messages will identify the hazard, tell you how to reduce the chance of injury, and tell you what can happen if the safety instructions are not followed.

CODE SYMBOLS



Hazard. Possible consequences : death or severe injuries.



Hazardous situation. Possible consequences : slight or mild injuries.



Dangerous situation. Possible consequences : damage to the drive or the environment.



Important instructions on protection against explosion.

Improper environment, installation and operation can result in severe personal injury and/or damage to property.

Qualified personnel must perform all work to assemble, install, operate, maintain and repair air motor.

Qualified personnel must follow:

- These instructions and the warning and information labels on the motor.
- All other drive configuration documents, startup instructions and circuit diagrams.
- The system specific legal regulations and requirements.
- The current applicable national and regional specifications regarding explosion protection, safety and accident prevention.



Complete the following checklist prior to starting installation in a hazardous area. All actions must be completed in accordance with ATEX 100a.

Checklist for installation in hazardous areas:

- _____ Read air motor label to check that motor has been designed for use in a hazardous application:
 - Hazardous zone
 - Hazardous category
 - Equipment group
 - Temperature class
 - Maximum surface temperatures
- _____ Example:
Model designation: 1UP-NRV-10
Year manufactured: 2003
Gast Mfg. Corp.
II 2GD c +1C° Ta +40C°
Benton Harbor, MI USA
Telephone: 269.926.6171
- _____ * Legend:
 - II Equipment group II
 - 2 Equipment category 2
 - G Gas atmospheres
 - D Dust atmospheres
 - c Constructional safety
 - +1CTa +40C* Max. surface temp. 275°F/135°C
 - Ambient range +1C° to +40°C (34°F/104°F)
- _____ Check the site environment for potentially explosive oils, acids, gases, vapors or radiation
- _____ Check the ambient temperature of the site and the ability to maintain proper ambient temperature.
Ambient range:
Normal conditions: 34°F/1°C to 250°F/121°C
Hazardous conditions: 34°F/1°C to 104°F/40°C
- _____ Check the site to make sure that the air motor will be adequately ventilated and that there is no external heat input (e.g. couplings). The cooling air may not exceed 104°F/40°C.
- _____ Check that products to be driven by the air motor meet ATEX approval.
- _____ Check that the air motor is not damaged.

INSTALLATION

Correct installation is your responsibility. Make sure you have the proper installation conditions.



WARNING



Injury Hazard



Install proper guards around output shaft as needed.

Air stream from product may contain solid or liquid material that can result in eye or skin damage.

Wear proper eye protection when installing this product.

Failure to follow these instructions can result in serious injury or property damage.

Mounting

This product can be installed in any orientation. Mount the motor to a solid metal base plate that is mounted to a stable, rigid operating surface. Use shock mounts to reduce noise and vibration. Install a pressure regulator or simple shut-off valve to control motor.

Connection

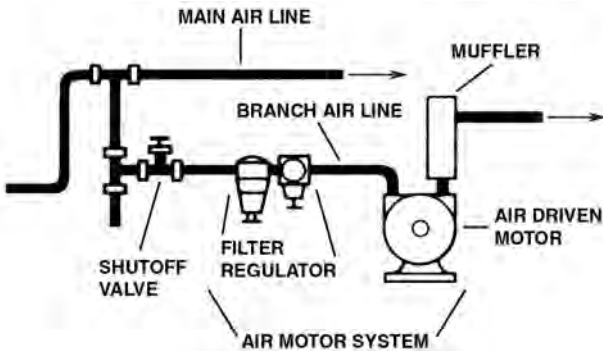

Check the direction of the motor airflow. A single rotation motor will operate properly only in one direction.

Single rotation motors require a sound absorber to be connected to the exhaust air port. Remove the plastic shipping plugs from the ports. Save plugs for future use during shutdown.

Install a 5-micron filter in the air line before the connection to the motor. Next install an air pressure regulator to control motor speed and torque.

Clean the compressed air connection with low pressure air to remove any dirt from the line before connecting to the ports.

Use the proper sized fasteners. For the most efficient output and control of speed, use air lines that are the same size as the motor inlet port if the connection is less than 7 feet (2 meters). For longer connections, use the next pipe size larger than the motor intake port. Connect lines to motor in the proper direction.

Connect the sound absorber on the exhaust air port or valve connection.

Do not add any thrust to the end or side of the shaft when making connections.



Do not use a hammer on the shaft or connections.



Lubricating the drive shaft will make assembly easier. Use a puller for removal of pulleys, couplings and pinions on the motor shaft. Check that the tension on the belt pulley matches the manufacturer's specifications. Do not exceed the maximum radial and axial forces on the shaft. If the motor shaft is connected to the part to be driven without a coupling, check that the radial offset and axial force effect will not cause problems.



Use only belts with 10^9 electrical leakage resistance to prevent static electrical problems. Ground the motor.

Accessories

A muffler is shipped with the air motor (except 16AM) but is not installed. Consult your Gast Distributor/Representative for additional filter recommendations. Install a moisture trap and 5 micron filter in the air line ahead of motor.

Air consumption data at various speeds and pressures are available from your Gast Distributor/Representative or the factory.

OPERATION



WARNING

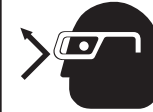

Injury Hazard

Air stream from product may contain solid or liquid material that can result in eye or skin damage. DO NOT use combustible gases to drive this motor.

Wear hearing protection. Sound level from motor may exceed 85 db(A).

Failure to follow these instructions can result in burns, eye injury or other serious injury.

Check all connections before starting motor. It is your responsibility to operate this product at recommended speeds, loads and room ambient temperatures. Do not run the motor at high speeds with no load. This will result in excessive internal heat that may cause motor damage.

The starting torque is less than the running torque. The starting torque will vary depending upon the position of the vanes when stopped in relation to the air intake port.

Use a pressure regulator and/or simple shut-off valve to regulate the motor's speed and torque. This will provide the required power and will conserve air. Open the air supply valve to the motor. Set the pressure or flow rate to the required speed or torque.



Operate the motor for approximately 2 hours at the maximum desired load. Measure the surface temperature of the motor on the casting opposite the pipe ports. The maximum surface temperature listed on the motor is for normal environmental and installation conditions. For most air motors, the maximum surface temperature should not exceed 266°F/130°C. Do not continue to operate the motor if the measured surface temperature exceeds temperature listed on the motor. If your measured temperature does exceed listed value, consult with your Gast Distributor/Representative for a recommendation.

MAINTENANCE



WARNING

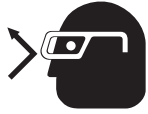

Injury Hazard



Disconnect air supply and vent all air lines.
Wear eye protection when flushing this product.
Air stream from product may contain solid or liquid material that can result in eye or skin damage.
Flush this product in a well ventilated area.
DO NOT use kerosene or other combustible solvents to flush this product.
Failure to follow these instructions can result in burns, eye injury or other serious injury.

It is your responsibility to regularly inspect and make necessary repairs to this product in order to maintain proper operation.

Check intake and exhaust filters after first 500 hours of operation. Clean filters and determine how frequently filters should be checked during future operation. This one procedure will help assure the motor's performance and service life.

Flushing

Flushing this product to remove excessive dirt, foreign particles, moisture or oil that occurs in the operating environment will help to maintain proper vane performance. Flush the motor if it is operating slowly or inefficiently.

Use only Gast recommended Flushing Solvent. DO NOT use kerosene or ANY other combustible solvents to flush this product.

1. Disconnect air line and muffler.
2. Add flushing solvent directly into motor. If using liquid solvent, pour several tablespoons directly into the intake port. If using spray solvent, spray for 5-10 seconds into intake port.
3. Rotate the shaft by hand in both directions for a few minutes.
4. **You must wear eye protection for this step.** Cover exhaust with a cloth and reconnect the air line.
5. Restart the motor at a low pressure of approximately 10 PSI/0.7 bar until there is no trace of solvent in the exhaust air.
6. Listen for changes in the sound of the motor. If motor sounds smooth, you are finished. If motor does not sound like it is running smoothly, installing a service kit will be required (See "Service Kit Installation").

Check that all external accessories such as relief valves or gauges are attached and are not damaged before operating product.

Cleaning sound absorber

1. Remove the sound absorber.
2. Clean the felt filter.
3. **You must wear eye protection for this step.**

4. Check the air compressor.
5. Listen for changes in the sound of the motor. If motor sounds smooth, you are finished. If motor does not sound like it running smoothly, installing a service kit will be required (See "Service Kit Installation").

Shutdown

It is your responsibility to follow proper shutdown procedures to prevent product damage.

1. Turn off air intake supply.
2. Disconnect air supply and vent all air lines.
3. Disconnect air lines.
4. Remove air motor from connecting machinery.
5. Remove the muffler.
6.  **Wear eye protection. Keep away from air stream.** Use clean, dry air to remove condensation from the inlet port of the motor.
7. Plug or cap each port.
8. Coat output shaft with oil or grease.
9. Store motor in a dry environment.

SERVICE KIT INSTALLATION

Gast will NOT guarantee field-rebuilt product performance. For performance guarantee, the product must be returned to a Gast Authorized Service Facility.

Service Kit contents vary. Most contain vanes, end cap gasket, body gasket, bearings and a muffler element or felt.

Major and Minor Rebuilds Tool kits which include a more in-depth rebuild manual are available through your Gast Distributor/Representative. These kits include the tools required to remove and reassemble end plates, bearings and shaft seals, and to set the proper end clearance. The rebuild manual also includes step by step instructions, including illustrations, to help achieve a successful rebuild. Gast Manufacturing, Inc. highly recommends using the air motor rebuild manual and tool kit when attempting a minor or major rebuild to your Gast air motor.

Minor Rebuild:

1. Remove the end cap.
2. Remove dead end plate bolts.
3. Remove dead end plate. (Use factory issued tool, do not use screwdriver to remove the end plate.)
4. Remove the dowel pins from the body and push back into end plate until flush or just below the machined surface of the end plate.
5. Remove vanes.
6. Clean parts. Check for scoring on the end plate and rotor assembly. If scoring exists, send unit to a Gast authorized service facility.
7. Install vanes. Angle cuts on vanes face to center of rotor.
8. Place the proper end plate gasket on the end plate. If the original is damaged, replace with a new one supplied in the Service Kit.
9. Place the dead end plate on the body.
10. Press the bearing onto the shaft using a factory supplied bearing pusher.

11. Tap dowel pins into body and install end plate bolts. Tighten bolts.
12. Set end clearance as required by model:
NL22-NL52 models - use the bearing taper from the Tool Kit to lightly tap on the inner race of the dead end bearing to free up and center the rotor in the body.
13. Reattach end cap.

Major Rebuild:

1. Remove the end cap.
2. Remove dead end plate bolts.
3. Remove dead end plate. (Use factory issued tool, do not use screwdriver to remove the end plate.)
4. Remove the dowel pins from the body and push back into end plate until flush or just below the machined surface of the dead end plate.
5. Remove rotor using an arbor press.
6. Remove vanes and ejection mechanism if reversible. (Ejection mechanisms may consist of vane springs, pins, caps or cam rings.)
7. Remove shaft seal and bearings from drive end plate and bearing from dead end plate. (Use factory issued tool.)
8. Do Not remove drive end plate bolts or drive end plate.
9. Clean parts. Check for scoring on the end plates and rotor assembly. If scoring exists, send unit to a Gast Authorized Service Facility.
10. Place the drive shaft of the rotor assembly through the drive end plate.
Press the drive bearing onto the drive shaft using a factory supplied bearing pusher.
11. Using the bearing taper from the Tool Kit, lightly tap on inner race of the drive end bearing to snug up rotor to drive end plate.
12. Install new vanes as required by model:
All single rotation units - the angle cuts on the vane face to center of the rotor.
13. Place the proper end plate gasket on the body of dead end. If the original is damaged, replace with a new one supplied in the service kit.
If your air motor uses O-rings, place the new O-rings in the body groove. Some models do not use end plate gaskets or O-rings.
14. Place the dead end plate on the body.
15. Install the dead end bearing and press into place with bearing pusher tool from tool kit.
16. Install the dowel pins.
17. Fully tighten the remaining bolts.
18. Set end clearance as required by model:
NL22-NL52 models - use the bearing taper from the Tool Kit to lightly tap on the inner race of the dead end bearing to free up and center the rotor in the body.
19. Apply a small amount of grease to bearing seal and install the drive end bearing seal by pressing flush with bearing pushing tool from Tool Kit.
20. Reattach end cap.



Disposal (Please note current regulations)

Parts of the air motor or air powered gear motor, shafts, cast iron or aluminum castings, gear wheels as well as rolling contact bearings may be recycled as scrap metal.

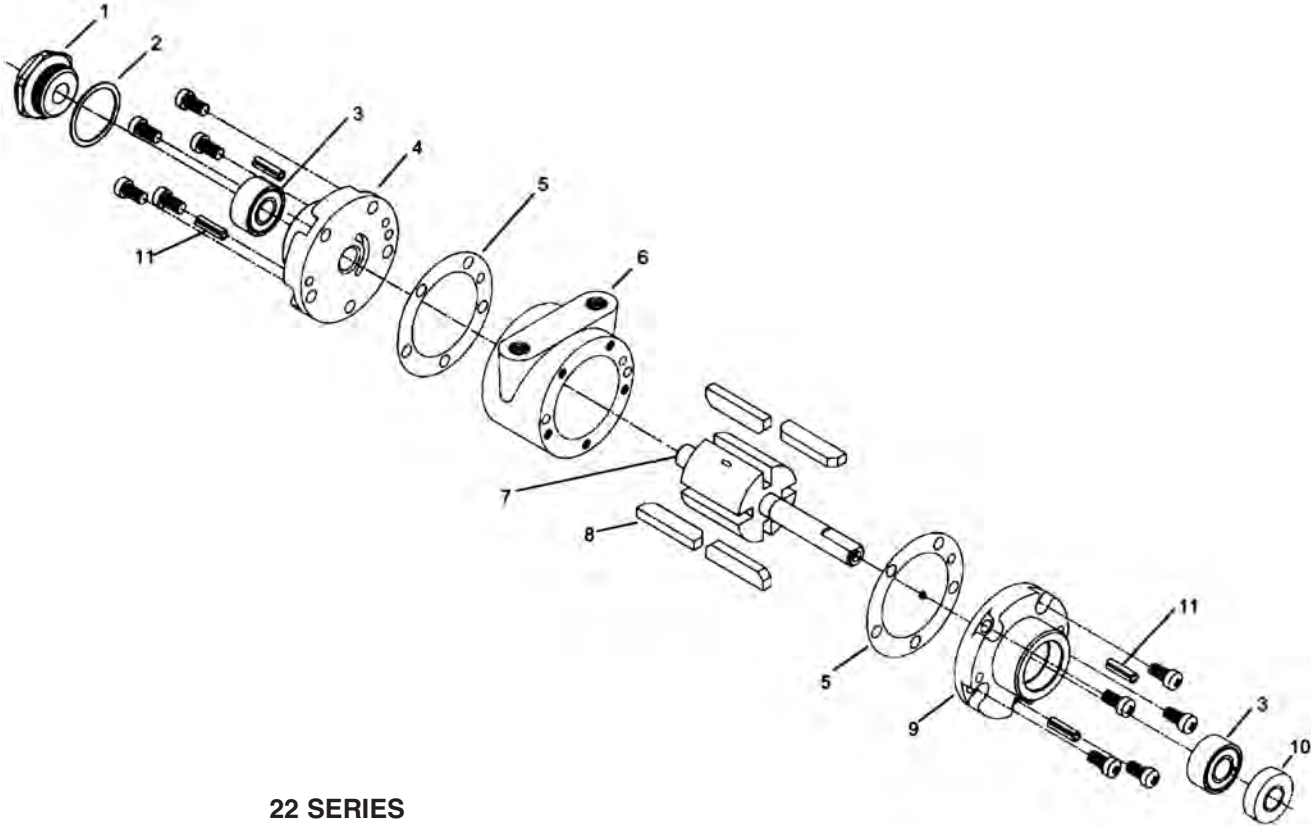
**22 SERIES**

REF#	DESCRIPTION	QTY	NL22-NCW-2 NL22-FCW-4*	NL22-NCC-1 NL22-FCC-3*
1	END CAP	1	AC228A	AC228A
2 Δ	END CAP GASKET	1	AC229	AC229
3 Δ	BEARING	2	AG549	AG549
4	DEAD END PLATE	1	AC192A	AC617
5 Δ	BODY GASKET (PRE 1998 MODELS)	2	AC527	AC527
6	BODY	1	AE899A	AE899A
7	ROTOR ASSEMBLY	1	AL335	AS334
8 Δ	VANES	4	AL306	AL306
9	DRIVE END PLATE	1	AC520B	AC616
10 Δ	SEAL	1	AC190A	AC190A
11	DOWEL PINS	1	D324A	D324A
***	MUFFLER ASSEMBLY	1	AF350	AF350
*** Δ	MUFFLER ELEMENT	1	AG896	AG896
***	SERVICE KIT	1	K285A	K285A
***	FOOT ASSEMBLY	1	AG585	AG585

*** Item not shown.

* Denotes model(s) that are supplied with Foot Assembly

Δ Denotes parts included in the Service Kit.

Parts listed are for stock models. For specific OEM models, please consult the factory. When corresponding about or ordering parts, please give complete model and serial numbers. Exploded views are shown for reference only. Units may vary depending upon specific model.

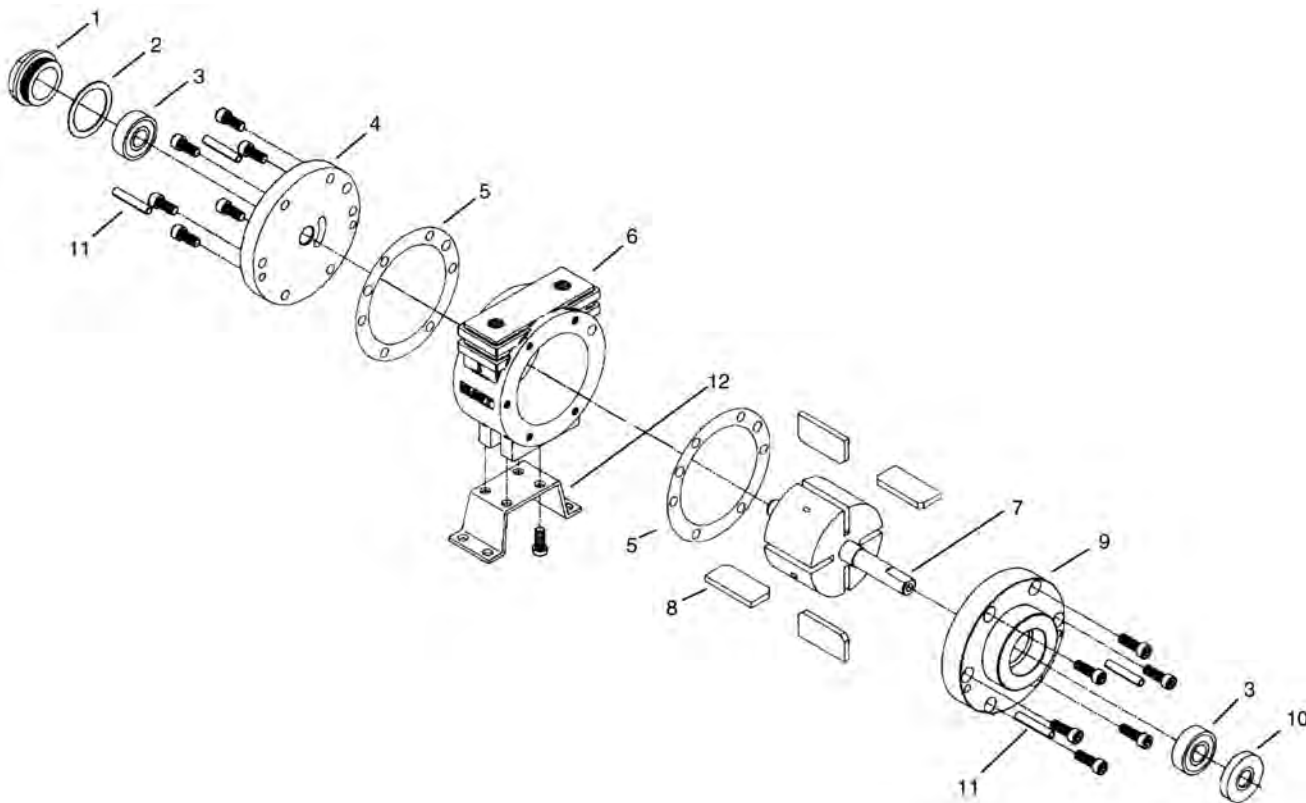

31 & 32 SERIES

REF#	DESCRIPTION	QTY	NL31-NCC-1	NL31-NCC-15	NL31-NCW-16	NL32-NCC-1	NL32-NCW-2 NL32-FCW-4*	NL32-NCC-5	NL32-NCW-6	NL32-NCC-7	NL32-NCW-8
1	END CAP	1	AM307D	AM307D	AM307D	AM307D	AM307D	AM307D	AM307D	AM307D	AM307D
2 Δ	END CAP GASKET	1	AA46	AA46	AA46	AA46	AA46	AA46	AA46	AA46	AA46
3 Δ	BEARING	2	AA299J	(1) AA299J (1) AB519	(1) AA299J (1) AB519	AA299J	AA299J	(1) AA299J (1) AB519	(1) AA299J (1) AB519	(1) AA299J (1) AB519	(1) AA299J (1) AB519
4	DEAD END PLATE	1	AK906	AK906	AK906A	AK906	AK906A	AK906	AK906A	AK906	AK906A
5 Δ	GASKET	1	B330	B330	B330	AK953A	AK953A	AK953A	AK953A	AK953A	AK953A
5 Δ		1				AK953B	AK953B	AK953B	AK953B	AK953B	AK953B
6	BODY	1	AK989B	AK989C	AK989C	AK989G	AK989G	AK989G	AK989G	AK989D	AK989D
7	ROTOR ASSEMBLY	1	AK951	AK990	AJ990A	AK324	AL325	AL404	AL405	AL326	AL327
8 Δ	VANES	4	AK988	AK988	AK988	AK988	AK988	AK988	AK988	AK988	AK988
9	DRIVE END PLATE	1	AK904	AK991	AK991A	AL320	AL321	AL322	AL323	AL322	AL323
10 Δ	SEAL	1	AA466B	B2328	B2328	AA466B	AA466B	B2328	B2328	B2328	B2328
11	DOWEL PINS	1	AB162 (4)	AB162 (4)	AB162 (4)	AB162	AB162	AB162	AB162	AB162	AB162
12	FOOT ASSEMBLY	1				AL220					
***	MUFFLER ASSEMBLY	1	AC980	AC980	AC980	AC980	AC980	AC980	AC980	AC980	AC980
*** Δ	MUFFLER ELEMENT	1	AC983	AC983	AC983	AC983	AC983	AC983	AC983	AC983	AC983
***	FLANGE	1						AK905A	AK905A	AK905	AK905
***	SERVICE KIT	1	K521	K522	K522	K521	K521	K522	K522	K522	K522

*** Item not shown.

* Denotes model(s) that are supplied with Foot Assembly

Δ Denotes parts included in the Service Kit.

Parts listed are for stock models. For specific OEM models, please consult the factory. When corresponding about or ordering parts, please give complete model and serial numbers. Exploded views are shown for reference only. Units may vary depending upon specific model.

EXPLODED PRODUCT VIEWS, PARTS & ORDERING INFORMATION 42 & 52 SERIES

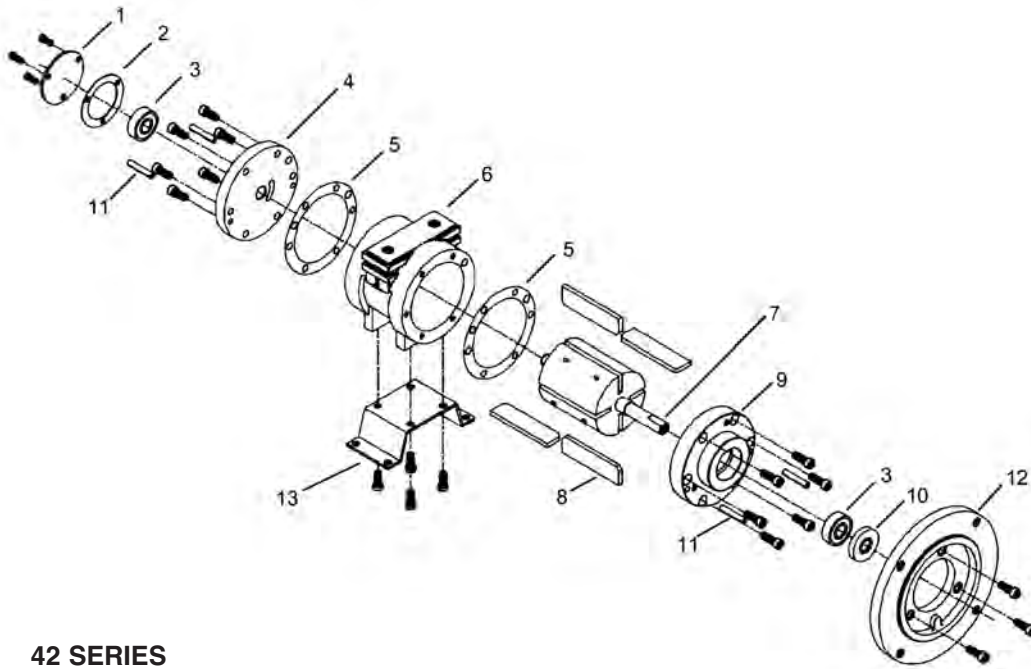

42 SERIES

REF#	DESCRIPTION	QTY	NL42-NCC-1 NL42-FCC-3*	NL42-NCW-2 NL42-FCW-4*	NL42-NCC-5	NL42-NCW-6	NL42-NCC-7	NL42-NCW-8
1	END CAP	1	AD643	AD643	AD643	AD643	AD643	AD643
2 Δ	END CAP GASKET	1	AD644	AD644	AD644	AD644	AD644	AD644
3 Δ	BEARING	2	AB519	AB519	AB519	AB519	AB519	AB519
4	DEAD END PLATE	1	AL356	AL357	AL356	AL357	AL356	AL357
5 Δ	GASKET	1	AK953A	AK953A	AK953A	AK953A	AK953A	AK953A
5 Δ		1	AL953B	AK953B	AK953B	AK953B	AK953B	AK953B
6	BODY	1	AL305	AL305	AL305	AL305	AL305B	AL305B
7	ROTOR ASSEMBLY	1	AL345	AL346	AL367	AL368	AL369	AL370
8 Δ	VANES	4	AL165	AL165	AL165	AL165	AL165	AL165
9	DRIVE END PLATE	1	AL349	AL350	AL349	AL350	AL349	AL350
10	SEAL	1	B2328	B2328	B2328	B2328	B2328	B2328
11	DOWEL PINS	1	AB162	AB162	AB162	AB162	AB162	AB162
12	FLANGE	1			AK905A	AK905A	AK905	AK905
13	FOOT ASSEMBLY	1	AL414	AL414				
***	MUFFLER ASSEMBLY	1	AC980	AC980	AC980	AC980	AC980	AC980
*** Δ	MUFFLER ELEMENT	1	AC983	AC983	AC983	AC983	AC983	AC983
***	SERVICE KIT	1	K580	K580	K580	K580	K580	K580

52 SERIES

REF#	DESCRIPTION	QTY	NL52-NCC-1	NL52-NCW-2	NL52-NCC-3	NL52-NCW-4	NL52-NCC-5	NL52-NCW-6
1	END CAP	1	AD643	AD643	AD643	AD643	AD643	AD643
2 Δ	END CAP GASKET	1	AD644	AD644	AD644	AD644	AD644	AD644
3 Δ	BEARING	2	AB519	AB519	AB519	AB519	AB519	AB519
4	DEAD END PLATE	1	AL587A	AL587	AL587A	AL587	AL587A	AL587
5 Δ	GASKET	1	B330F	B330F	B330F	B330F	B330F	B330F
5 Δ		1	B330G	B330G	B330G	B330G	B330G	B330G
6	BODY	1	AL589	AL589	AL589	AL589	AL589	AL589
7	ROTOR ASSEMBLY	1	AL586A	AL586	AL586A	AL586	AL586A	AL586
8 Δ	VANES	4	AL585	AL585	AL585	AL585	AL585	AL585
9	DRIVE END PLATE	1	AL588A	AL588	AL588A	AL588	AL588A	AL588
10 Δ	SEAL	1	B2328	B2328	B2328	B2328	B2328	B2328
11	DOWEL PINS	1	AB162	AB162	AB162	AB162	AB162	AB162
12	FLANGE	1			AK905A	AK905A	AL596	AL596
***	MUFFLER ASSEMBLY	1	AC990	AC990	AC990	AC990	AC990	AC990
*** Δ	MUFFLER ELEMENT	1	AC993	AC993	AC993	AC993	AC993	AC993
***	SERVICE KIT	1	K833	K833	K833	K833	K833	K833

*** Item not shown.

* Denotes model(s) that are supplied with Foot Assembly

Δ Denotes parts included in the Service Kit.

Parts listed are for stock models. For specific OEM models, please consult the factory. When corresponding about or ordering parts, please give complete model and serial numbers. Exploded views are shown for reference only. Units may vary depending upon specific model.

TROUBLESHOOTING CHART

Problem					
Low Torque	Low Speed	Won't Run	Runs Hot	Runs Well Then Slows Down	Reason & Remedy For Problem.
.	.	.			Dirt or foreign material present. Inspect and clean.
.	.	.			Internal rust. Inspect and clean.
.	Vanes misaligned. Realign vanes.
.	.				Low air pressure. Increase pressure.
	.				Air line too small. Install larger line(s).
	.			.	Restricted exhaust. Inspect and repair.
.	.	.		.	Motor is jammed. Disassemble and repair.
	.			.	Air source inadequate. Inspect and repair.
	.			.	Air source too far from motor. Reconfigure setup.

For the name of the nearest authorized service facility, contact one of our offices below or visit our website at www.gastmfg.com.

Gast Manufacturing, Inc.
 2300 S. Highway M139
 Benton Harbor, MI 49022
 Ph: 269/926-6171
 FAX: 269/925-8288
www.gastmfg.com

Gast Hong Kong
 Unit 12, 21/F, Block B
 New Trade Plaza
 6, On Ping Street, Shatin
 N. T. Hong Kong
 Ph: (852) 2690 1008
 Fax: (852) 2690 1012
www.gasthk.com

European Sales & Service Headquarters
 Gast Group Limited
 A Unit of IDEX Corporation
 Unit 11, The I O Centre
 Nash Road
 Redditch B98 7AS
 United Kingdom
 Tel: +44 (0) 1527 504040
 Fax: +44 (0) 1527 525262
www.gastmfg.com
www.jun-air.com



ISO 9001 & 14001 CERTIFIED

www.gastmfg.com