

GAST LUBRICATED 23 SERIES LABORATORY ROTARY VANE VACUUM PUMPS & COMPRESSORS

OPERATION & MAINTENANCE MANUAL

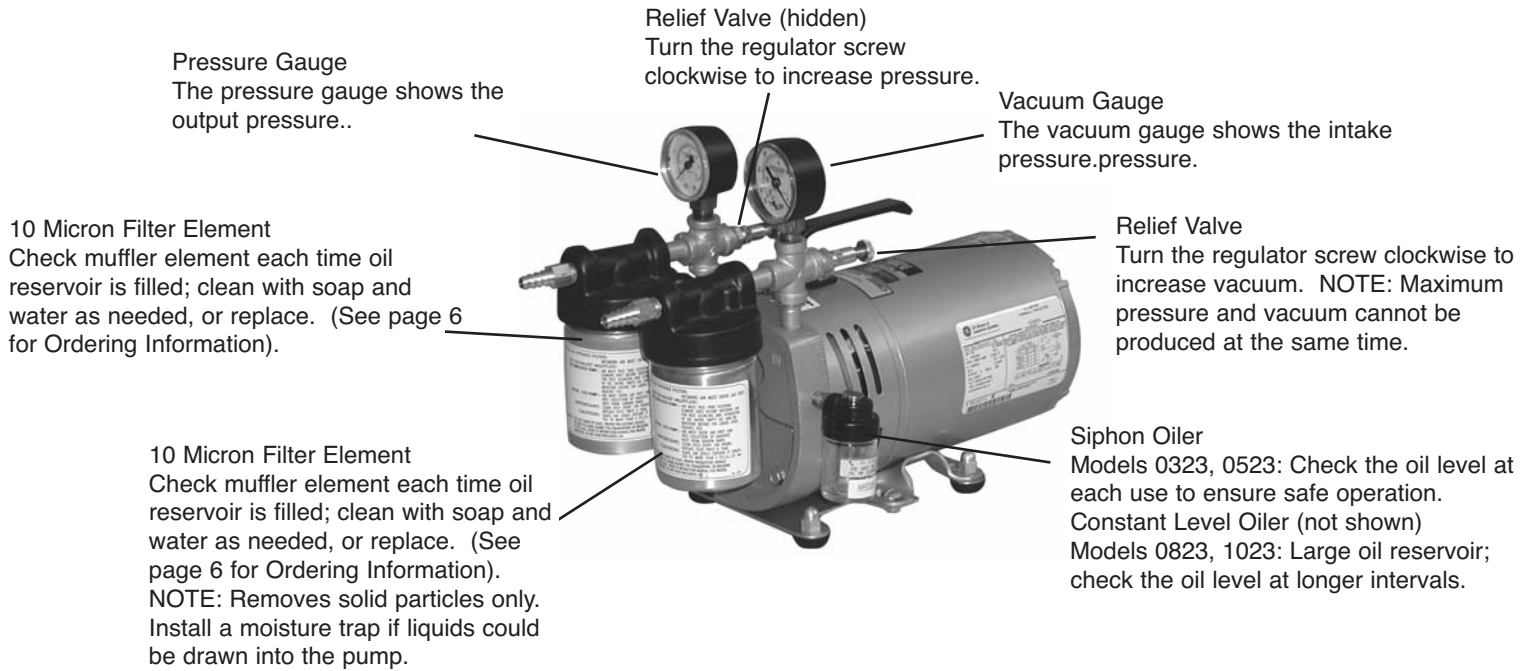

Pressure Gauge
The pressure gauge shows the output pressure..

Relief Valve (hidden)
Turn the regulator screw clockwise to increase pressure.

Vacuum Gauge
The vacuum gauge shows the intake pressure.pressure.

10 Micron Filter Element
Check muffler element each time oil reservoir is filled; clean with soap and water as needed, or replace. (See page 6 for Ordering Information).

Relief Valve
Turn the regulator screw clockwise to increase vacuum. NOTE: Maximum pressure and vacuum cannot be produced at the same time.

10 Micron Filter Element
Check muffler element each time oil reservoir is filled; clean with soap and water as needed, or replace. (See page 6 for Ordering Information).
NOTE: Removes solid particles only. Install a moisture trap if liquids could be drawn into the pump.

Siphon Oiler
Models 0323, 0523: Check the oil level at each use to ensure safe operation. Constant Level Oiler (not shown) Models 0823, 1023: Large oil reservoir; check the oil level at longer intervals.

WARNING



PLEASE READ THIS MANUAL COMPLETELY BEFORE INSTALLING AND USING THIS MOTOR. SAVE THIS MANUAL FOR FUTURE REFERENCE AND KEEP IN THE VICINITY OF THE MOTOR.

Product Use Criteria:

General information

- **Clearances:** 0323/0523
 Top: .002"
 End: .0025" - .0035"
 Drive: .001"

- 0823/1023
 Top: .003"
 Ends: .0040" - .0050"
 Drive: .0015"

- **Vane Life:** 5,000 - 15,000 hours depending upon application

- Operate at 32°F - 104°F (0°C - 40°C).
- Protect unit from dirt & moisture.
- Protect all surrounding items from hot exhaust air. This exhaust air can become very hot.
- Product is not a consumer product and is for commercial applications only.

- **Do not pump flammable or explosive gases or use**

- Corrosive gases and particulate material will damage unit. Water vapor, oil-based contaminants or other liquids must be filtered out.
- Consult your Gast Distributor/Representative before using at high altitudes.
- Use Gast #AD220 or a detergent SAE#10 automotive engine oil for lubricating.



ISO 9001 & 14001 CERTIFIED

www.gastmfg.com

Your safety and the safety of others is extremely important.

We have provided many important safety messages in this manual and on your product. Always read and obey all safety messages.



This is the safety alert symbol. This symbol alerts you to hazards that can kill or hurt you and others. The safety alert symbol and the words "DANGER" and "WARNING" will precede all safety messages. These words mean:

! DANGER

You will be killed or seriously injured if you don't follow instructions.

! WARNING

You can be killed or seriously injured if you don't follow instructions.

All safety messages will identify the hazard, tell you how to reduce the chance of injury, and tell you what can happen if the safety instructions are not followed.

INSTALLATION

! WARNING



Electrical Shock Hazard

Disconnect electrical power at the circuit breaker or fuse box before installing this product.

Install this product where it will not come into contact with water or other liquids.

Install this product where it will be weather protected.

Electrically ground this product.

Failure to follow these instructions can result in death, fire or electrical shock.

Correct installation is your responsibility. Make sure you have the proper installation conditions and that installation clearances do not block air flow. Proper guards should be installed to prevent contact with moveable parts of this pump. Do Not lift the unit by the fan shroud.

Blocking air flow over the product in any way can cause the product to overheat.

Mounting

Position the mounting the product to a stable, rigid operating surface and using shock mounts will reduce noise and vibration.

Mounting

The pump and its solid base (preferably metal) should be anchored to either a shelf, the floor, or another piece of machinery. To save time and avoid inconvenience, position the pump to provide easy access to all lubricators, filters and mufflers.

Moisture Trap

Liquid or moisture vapor will damage the pump. Install a moisture trap if liquids could be drawn into the pump. For the correct type and size, contact your local Distributor or the factory.

Plumbing

To prevent air flow restriction, use pipe and fittings that are the same size or larger than the threaded ports of the pump. The ports are marked "IN" and "OUT". If the distance is great, use lines with a larger diameter than the connections. Give lines a uniform slope, place drain cock at low point, and avoid extra elbows. For ease of servicing, use a union or hose with clamps near the pump (a hose helps eliminate noise and vibration). If a vacuum/pressure supply tank is used, slope the line towards tank, provide a drain at the bottom, and place a check valve between the tank and pump so the pump will not run backwards when turned off.

Motor Control

It is your responsibility to contact a qualified electrician to assure that the electrical installation is adequate and in conformance with all national and local codes and ordinances.

Determine the correct overload setting required to protect the motor (see motor starter manufacturer's recommendations). Select fuses, motor protective switches or thermal protective switches to provide protection. Fuses act as short circuit protection for the motor, not as protection against overload. Incoming line fuses help to withstand the motor's starting current. Motor starters with thermal magnetic overload or circuit breakers protect motor from overload or reduced voltage conditions.

The wiring diagram supplied with the product provides required electrical information. Check that power source is correct to properly operate the dual-voltage motors.

Electrical Connection

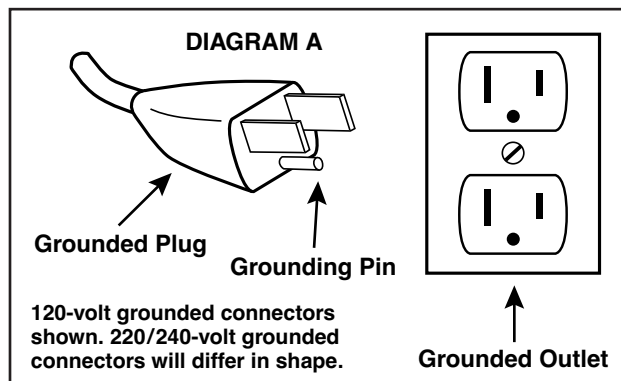

Model with a power supply cord:

This product must be grounded. For either 120-volt or 220/240-volt circuits connect power supply cord grounding plug to a matching grounded outlet. Do not use an adapter. (See DIAGRAM A)

In the event of an electrical short circuit, grounding reduces the risk of electric shock by providing an escape wire for the electric current. This product may be equipped with a power supply cord having a grounding wire with an appropriate grounding plug. The plug must be plugged into an outlet that is properly installed and grounded in accordance with all local codes and ordinances.

Check with a qualified electrician or serviceman if the grounding instructions are not completely understood, or if you are not sure whether the product is properly grounded. Do not modify the plug provided. If it will not fit the outlet, have the proper outlet installed by a qualified electrician.

Model that is permanently wired:

This product must be connected to a grounded, metallic, permanent wiring system, or an equipment grounding terminal or lead on the product.

Power supply wiring must conform to all required safety codes and be installed by a qualified person. Check that supply voltage agrees with that listed on product nameplate.

Extension cords:

Use only a 3-wire extension cord that has a 3-blade grounding plug. Connect extension cord plug to a matching 3-slot receptacle. Do not use an adapter. Make sure your extension cord is in good condition. Check that the gage wire of the extension cord is the correct size wire to carry the current this product will draw.

Minimum gage for extension cords										
Amps	Volts	Length of cord in feet								
	120v	25	50	100	150	200	250	300	400	500
	240v	50	100	200	300	400	500	600	800	1000
0-2		18	18	18	16	16	14	14	12	12
2-3		18	18	16	14	14	12	12	10	10
3-4		18	18	16	14	12	12	10	10	8
4-5		18	18	14	12	12	10	10	8	8
5-6		18	16	14	12	10	10	8	8	8
6-8		18	16	12	10	10	8	6	6	6
8-10		18	14	12	10	8	8	6	6	4
10-12		16	14	10	8	8	6	6	4	4
12-14		16	12	10	8	6	6	6	4	2
14-16		16	12	10	8	6	6	4	4	2
16-18		14	12	8	8	6	4	4	2	2
18-20		14	12	8	6	6	4	4	2	2

OPERATION

WARNING



Injury Hazard

Pump only clean dry air.

Do not pump flammable or explosive gases or use in an atmosphere that contains such gases.

Do not spray flammable or combustible liquid.

Air stream from product may contain solid or liquid material that can result in eye or skin damage.

Install proper safety guards as needed. Pumps with glass jars need safety guards to protect against breaking glass.

Use only recommended air handling parts acceptable for pressure not less than 70 psi.

Keep fingers and objects away from openings and rotating parts.

When provided, motor terminal covers must be in place for safe operation.

Check that coupling guard and shroud are in place before operating.

Product surfaces may become hot during operating, allow product surfaces to cool before handling.

Do not direct air stream at body. Air stream from product may contain solid or liquid material that can result in eye or skin damage, wear proper eye protection.

Wear hearing protection. Sound level from product may exceed 85 db(A).

Failure to follow these instructions can result in eye injury or other serious injury.

It is your responsibility to operate this product at recommended pressures or vacuum duties and room ambient temperatures. Do Not start against a vacuum or pressure load.

Start Up

If pump is extremely cold, let it warm up to room temperature before starting. If motor fails to start or slows down significantly under load, shut off and disconnect from power supply. Check that the voltage is correct for motor and that motor is turning in the proper direction. Turning in the wrong direction will drastically reduce vane life. Vane life will be drastically reduced if motor is not operating properly. Vanes can break or be damaged if motor/pump runs in the wrong direction.

MAINTENANCE

WARNING



Electrical Shock Hazard

Disconnect electrical power supply cord before performing maintenance on this product.

If product is hard wired into system, disconnect electrical power at the circuit breaker or fuse box before performing maintenance on this product.

Failure to follow these instructions can result in death, fire or electrical shock.

 **WARNING**

Injury Hazard

Wear eye protection when flushing this product.

Air stream from product may contain solid or liquid material that can result in eye or skin damage.

Flush this product in a well ventilated area.

Do Not use kerosene or other combustible solvents to flush this product.

Failure to follow these instructions can result in eye injury or other serious injury.

It is your responsibility to:

- Regularly inspect and make necessary repairs to product in order to maintain proper operation.
- Make sure that pressure and vacuum is released from product before starting maintenance.

 **WARNING**

The pump surfaces may become very hot during operation. do not touch these parts until the pump has been turned off and allowed to cool.

Check intake and exhaust filters after first 500 hours of operation. Clean filters and determine how frequently filters should be checked during future operation. **This one procedure will help to assure the product's performance and service life.**

Clean filters when necessary by removing and washing in a solvent or soap and water. After cleaning, dry with compressed air to make sure all moisture is removed before replacing filters.

Flushing

Flushing this product to remove excessive dirt, foreign particles, moisture or oil that occurs in the operating environment will help to maintain proper vane performance. If your pump is not getting the vacuum or pressure level expected, flushing is required. Vanes will stick when dirty and may cause pump to be noisy or inefficient.

Use only Gast Flushing Solvent or other non-petroleum based flushing solvent. Do Not use kerosene or ANY other combustible solvent to flush product.

1. Disconnect electrical power supply.
2. Release all pressure and vacuum from pump.
3. Remove all accessories at the inlet and exhaust ports.
4. Remove filter.
5. Start product. Place towel over exhaust port to clean up solvent. If using liquid solvent, pour several tablespoons directly into inlet port. If using Gast Flushing Solvent, spray solvent for 5-10 seconds into inlet port.
6. Block the inlet port and draw a deep vacuum for 15-20 seconds. Release the vacuum.
7. Listen for changes in the sound of the motor. If motor sounds smooth, go to next step. If motor does not sound like it is running smoothly, repeat steps 5 and 6 until you can hear a difference in the operating sound of the pump.
8. Start the pump and let it run for 1 minute, then turn pump off.
9. Replace all accessories at the inlet and exhaust ports.
10. Replace filter before resuming operation.

Check that all external accessories such as relief valves and gauges are attached to cover and are not damaged before re-operating product.

SHUTDOWN PROCEDURES

It is your responsibility to follow proper shutdown procedures to prevent product damage.

Failure to do so may result in premature pump failure. The Gast Manufacturing lubricated Vacuum Pumps and Compressors are constructed of ferrous metals or aluminum which are subject to rust and corrosion when pumping condensable vapors such as water. Follow the steps below to assure correct storage and shutdown between operating periods

1. Disconnect plumbing.
2. Allow the pump to run "open" for at least 5 minutes.
3. Fill oil reservoir to proper level
4. Cover inlet port (vacuum side) and run pump for 1-3 minutes. Shut the pump down under vacuum.
5. Plug ports so dirt or other contaminants do not enter unit. It is now ready for shut-down

SERVICE KIT INSTALLATION

WARNING



Electrical Shock Hazard

Disconnect electrical power supply cord before installing Service Kit.

If product is hard wired into system, disconnect electrical power at the circuit breaker or fuse box before installing Service Kit.

Disconnect air supply and vent all air lines to release pressure or vacuum.

Failure to follow these instructions can result in death, fire or electrical shock.

Gast will NOT guarantee field-rebuilt product performance. For performance guarantee, the product must be returned to a Gast Authorized Service Facility.

Service Kit contents vary. Most contain vanes, gaskets oiler wick and filter elements.

Do Not attempt to remove the rotor. It is held in place by Loctite and can only be serviced by a Gast Authorized Service Facility.

PUMP DISASSEMBLY

1. Remove the 6 cap screws from the pump end plate and remove the end plate.
DO NOT at any time remove the rotor or loosen any of the electric motor thru-bolts.
2. Check for scoring on End Plate, Rotor, and Body. Surfaces should be smooth. If severe scoring is visible contact an Authorized Service Facility.
3. Remove vanes.
4. Clean all surfaces with Gast recommended Flushing solvent and dry well.

PUMP RE-ASSEMBLY

5. Apply a light coat of Gast recommended Oil part#AD220,(an equivalent 10 wt. high detergent oil can also be used) to the vanes.
6. Re-install vanes, noting the proper direction of the beveled edge (Refer to exploded view).
7. Install End Plate with the six (6) cap screws.
Torque the screws to 100 lb.-in.

If the pump fails to produce proper vacuum or pressure, or is excessively noisy, turn off and return unit to an Authorized Service Facility.



Disposal (Please note current regulations)

Parts of the rotary vane pumps and compressors, shafts, iron or aluminum castings, plastic or glass parts or bearings, may be recycled as scrap materials.

We have Gast Certified Service Centers throughout the world. For the most up-to-date listing, contact one of our sales offices below:

World Headquarters

P.O. Box 97
2300 Highway M139
Benton Harbor, MI 49022
Ph: 269/926-6171
FAX: 269/925-8288
www.gastmfg.com

Gast Group Limited, United Kingdom

Unit 11, The I O Centre
Nash Road
Redditch, B98 7AS
United Kingdom
ph: +44 (0) 1527 504040
Fax: +44 (0) 1527 525262
www.gastmfg.com

Gast Hong Kong

Unit 12, 21/F, Block B
New Trade Plaza
6, On Ping Street, Shatin
N. T. Hong Kong
Ph: (852) 2690 1008
Fax: (852) 2690 1012
www.gasthk.com

Series 0323 and 0523:

These models use a siphon oiler. The lubrication rate is determined by the temperature, the operating vacuum or pressure, and the siphon jar oil level. Keep the siphon jar filled to the line shown on the jar. Either unscrew the jar or fill through the spring-loaded cap.

All Models:

The oil wick should be folded in half, with the two ends submerged in the oil at the bottom of the Jar, and the folded center inserted into the connector approximately 3/8" past the two breather holes in the connector (but not touching the feed hole leading to the pump). Both the breather holes and the feed hole must be unrestricted.

Series 0823 and 1023:

These models use a constant level oiler. The lubrication rate is determined by the temperature, the vacuum or pressure at which the pump is operating, and the siphon jar oil level (determined by the vertical position of the tube in the jar).

The lower end of the tube should be 1/4" from the bottom of the oil jar for normal lubrication. To reposition the tube, loosen the locknut and adjust the sleeve up or down. Lock the new position with the locknut. For faster lubrication, raise the reservoir tube away from the bottom of the oil jar. For slower lubrication, lower the reservoir tube toward the bottom of the jar.

To replenish the oil, pull the reservoir upward out of the adjusting sleeve and turn it over. Add oil through the tube. When the upper reservoir is filled, replace it through the adjusting sleeve and firmly seat it against the top of the sleeve.

All Models:

The oil wick should be folded in half, with the two ends submerged in the oil at the bottom of the Jar, and the folded center inserted into the connector approximately 3/8" past the two breather holes in the connector (but not touching the feed hole leading to the pump). Both the breather holes and the feed hole must be unrestricted.

EXPLODED PRODUCT VIEW, PARTS & ORDERING INFORMATION

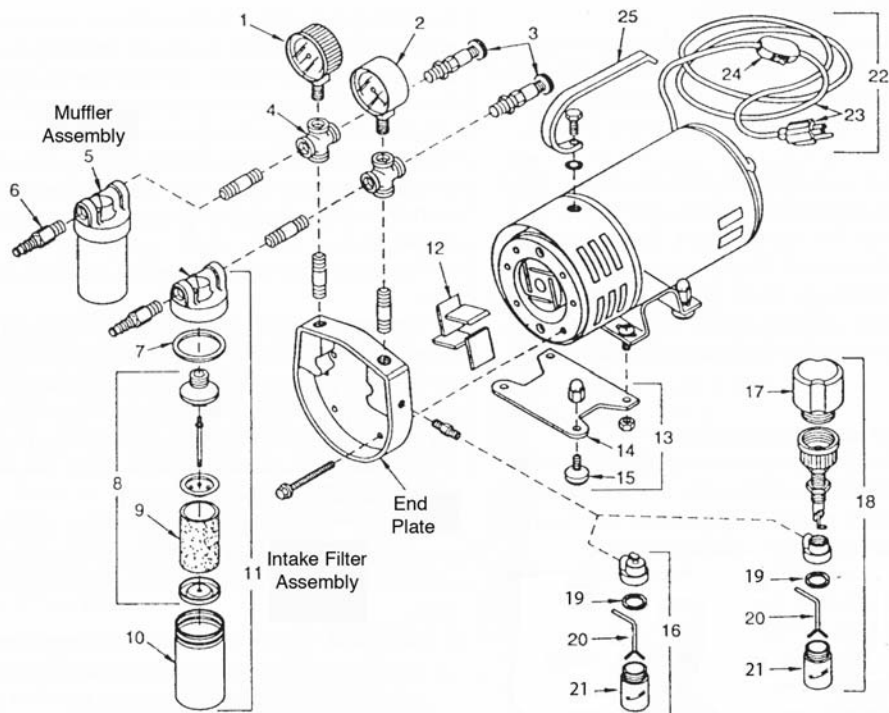

(Figure 1)

0323/0523/0823/1023 SERIES

REF NO.	DESCRIPTION	QTY	0323-V4 0523-V4A	0823-V4B 1023-V4
1	PRESSURE GAUGE	1	AA644B	AA644B
2	VACUUM GAUGE	1	AA640	AA640
3	REGULATOR	2	AA096B	AK502
	PRESSURE RELIEF VALVE	1	--	AA600
	VACUUM RELIEF VALVE	1	--	AA840
4	CROSS	2	BA601	BA602
5	MUFFLER ASSEMBLY	1	AB609B	AB608A
6	HOSE NIPPLE	2	AA254D	AA239
7 Δ	COVER GASKET	2	AA404	AA404
	INTAKE FILTER	1	AC433-1	AC433-1
8	ELEMENT ASSEMBLY			
	MUFFLER	1	AC434-1	AC434-1
9Δ	CARTRIDGE	2	AC393	AC393
10	METAL JAR	2	AA132	AA132
11	INTAKE FILTER ASSM.	1	AB609D	AB608B
12 Δ	VANE	4	AK731	AK741
13	FOOT SUPPORT ASSEMBLY	1	AC136	--
14	FOOT SUPPORT	1	AC135	--
15	RUBBER FOOT	4	--	AB319
16	SIPHON OILER	1	AA930B	
17	OIL RESERVOIR	1	--	AD117
18	CONSTANT LEVEL OILER	1	--	AK125K
19	COVER GASKET - OILER	1	AA932	AA932
20Δ	WICK	1	AA934	AA934
21	JAR	1	AA935A	AA935A
22	CORD/SWITCH/PLUG ASSM	1	AA896	AL239 (0823-V4B ONLY)
23	CORD/PLUG ASSEMBLY	1	--	AL142 (0823-V4B ONLY)
24	SWITCH	1	--	AC169 (0823-V4B ONLY)
25	HANDLE	1	AC174	AF555
***	SERVICE KIT	1	K556A	K486

WARRANTY

Gast finished products, when properly installed and operated under normal conditions of use, are warranted by Gast to be free from defects in material and workmanship for a period of twelve (12) months from the date of purchase from Gast or an authorized Gast Representative or Distributor. In order to obtain performance under this warranty, the buyer must promptly (in no event later than thirty (30) days after discovery of the defect) give written notice of the defect to Gast Manufacturing Incorporated, PO Box 97, Benton Harbor Michigan USA 49023-0097 or an authorized Service Center (unless specifically agreed upon in writing signed by both parties or specified in writing as part of a Gast OEM Quotation). Buyer is responsible for freight charges both to and from Gast in all cases.

This warranty does not apply to electric motors, electrical controls, and gasoline engines not supplied by Gast. Gast's warranties also do not extend to any goods or parts which have been subjected to misuse, lack of maintenance, neglect, damage by accident or transit damage.

THIS EXPRESS WARRANTY EXCLUDES ALL OTHER WARRANTIES OR REPRESENTATIONS EXPRESSED OR IMPLIED BY ANY LITERATURE, DATA, OR PERSON. GAST'S MAXIMUM LIABILITY UNDER THIS EXCLUSIVE REMEDY SHALL NEVER EXCEED THE COST OF THE SUBJECT PRODUCT AND GAST RESERVES THE RIGHT, AT ITS SOLE DISCRETION, TO REFUND THE PURCHASE PRICE IN LIEU OF REPAIR OR REPLACEMENT.

GAST WILL NOT BE RESPONSIBLE OR LIABLE FOR INDIRECT OR CONSEQUENTIAL DAMAGES OF ANY KIND, however arising, including but not limited to those for use of any products, loss of time, inconvenience, lost profit, labor charges, or other incidental or consequential damages with respect to persons, business, or property, whether as a result of breach of warranty, negligence or otherwise. Notwithstanding any other provision of this warranty, BUYER'S REMEDY AGAINST GAST FOR GOODS SUPPLIED OR FOR NON-DELIVERED GOODS OR FAILURE TO FURNISH GOODS, WHETHER OR NOT BASED ON NEGLIGENCE, STRICT LIABILITY OR BREACH OF EXPRESS OR IMPLIED WARRANTY IS LIMITED SOLELY, AT GAST'S OPTION, TO REPLACEMENT OF OR CURE OF SUCH NONCONFORMING OR NON-DELIVERED GOODS OR RETURN OF THE PURCHASE PRICE FOR SUCH GOODS AND IN NO EVENT SHALL EXCEED THE PRICE OR CHARGE FOR SUCH GOODS. GAST EXPRESSLY DISCLAIMS ANY WARRANTY OF MERCHANTABILITY OR FITNESS FOR A PARTICULAR USE OR PURPOSE WITH RESPECT TO THE GOODS SOLD. THERE ARE NO WARRANTIES WHICH EXTEND BEYOND THE DESCRIPTIONS SET FORTH IN THIS WARRANTY, notwithstanding any knowledge of Gast regarding the use or uses intended to be made of goods, proposed changes or additions to goods, or any assistance or suggestions that may have been made by Gast personnel.

Unauthorized extensions of warranties by the customer shall remain the customer's responsibility.

CUSTOMER IS RESPONSIBLE FOR DETERMINING THE SUITABILITY OF GAST PRODUCTS FOR CUSTOMER'S USE OR RESALE, OR FOR INCORPORATING THEM INTO OBJECTS OR APPLICATIONS WHICH CUSTOMER DESIGNS, ASSEMBLES, CONSTRUCTS OR MANUFACTURES.

This warranty can be modified only by authorized Gast personnel by signing a specific, written description of any modifications.

TROUBLESHOOTING CHART

Low		High		Pump Overheat	Motor Overload	Reason and remedy for problem.
Vacuum	Pressure	Vacuum	Pressure			
•	•	At pump		•	•	Filter dirty. Clean or replace.
	•		At pump	•	•	Muffler dirty. Clean or replace.
•		At pump		•	•	Vacuum line collapsed. Repair or replace.
•			•	•	•	Relief valve set too high. Inspect and adjust.
•	•					Relief valve set too low. Inspect and adjust.
•	•	At pump	At pump	•	•	Plugged vacuum/pressure line. Inspect and repair.
•	•					Vanes sticking. Clean or replace.
•	•					Vanes worn. Replace.
•	•					Shaft seal worn. Replace.
•	•			•	•	Dust or offset powder in pump. Inspect and clean.
•	•			•		Motor not wired correctly. Check wiring diagram and line voltage.
		•	•	•	•	Running at too high an RPM. Check wiring diagram and line voltage.