

Linear Compressors and Vacuum Pumps



The Gast Group Difference

For over 80 years, Gast Manufacturing has been providing innovative air solutions to a broad breadth of customers. With the relatively recent addition of JUN-AIR, we have expanded our capabilities and formed, “The Gast Group.” Together, our diverse engineering background and pneumatic experience allow us to provide both component and system solutions to meet all of your pneumatic needs. And, all backed by our strong commitment to quality and customer support.

Products for Almost Any Application – Worldwide

We offer an extensive and versatile line of air-moving products, including vacuum pumps, compressors, air motors, gearmotors, vacuum generators, and regenerative blowers. We design and build these components for original equipment manufacturers worldwide, but we also develop complete pneumatic solutions to solve tough customer challenges.

To ensure fast, efficient delivery of products, Gast has a vast network of sales representatives/distributors throughout the United States and the world. Plus, we maintain direct sales and service facilities in Europe, Hong Kong, and Shanghai, China.

Unparalleled Design Expertise

Unlike other manufacturers, who might expect you to modify your pneumatic system to fit their available product(s), Gast is committed to finding the right product to meet your specific needs. If we don't have a high-quality, off-the-shelf product to fit your existing application or meet your anticipated needs, we'll propose customized cost-effective design options that will serve your special requirements. We can even develop and produce your complete pneumatic system for you.

Our experienced Research and Development engineers and Product engineers work together to analyze customer needs and use computer-aided design to generate timely solutions for air-handling problems. The design team has one goal: to create problem-solving solutions that capitalize on the latest available technology, meet all application requirements, and benefit from cost-effective production methods. The end result: products and solutions that are the best value in the marketplace for our customers.

A Lasting Commitment to Quality

We invest heavily in both equipment and people to maintain the consistent quality for which our products are known worldwide, and we have done so since day one. As early as 1983, we implemented a total quality process designed to ensure the quality of our products. In keeping with that tradition, Gast has achieved ISO 9001 and 14001 certification, making us a member of the elite group of manufacturing companies in the world to receive that certification. ISO 9001 and 14001 are the most stringent of the three ISO quality standards.

European Community Directives

With extensive sales outside the United States, Gast has pledged to conform to the European Community Directives. These directives contain essential requirements concerning health, safety, environment, and consumer protection for all products targeted for the European Community market. Currently, all Gast products available for sale in the European Community are in compliance with the Machinery, Low Voltage, and Electromagnetic Compatibility Directives.

Pictorial and dimensional data is subject to change without notice. The information presented is based on technical data and test results of nominal units. It is believed to be accurate and is offered as an aid in the selection of Gast products. It is the user's responsibility to determine suitability of the product for intended use and the user assumes all risk and liability whatsoever in connection therewith. Environmental and application conditions may affect advertised life.

Why use a Linear Product?

Reliable

The moving parts consist of an actuating rod supported by two special synthetic rubber diaphragms. They oscillate laterally, permitting a minimum of 30,000 hours of continuous operation on many models. Other than the occasional filter cleaning, operation is virtually maintenance-free. Replacement parts come in a cassette.

Quiet

Sound insulation was a prime consideration in the design of the pneumatic circuit and mechanical section. The result: a surprisingly low operating noise level – as low as 38 dB(a).

Energy Efficient

Operation is based upon the principles of electromagnetic oscillation. It eliminates the need for sliding parts, minimizing power consumption.

Clean Air

Because there are no sliding parts there is no need for lubrication. An added advantage: the exhausted air is always clean and particle-free.

Smooth Flow

Uniform exhaust rate and minimal pulsation make the Linear products ideal for applications requiring consistent air pressure and supply.

Electromagnetic oscillation of the rod/diaphragm assembly changes the volume of space enclosed between the casing and the diaphragm, creating pressure or vacuum.

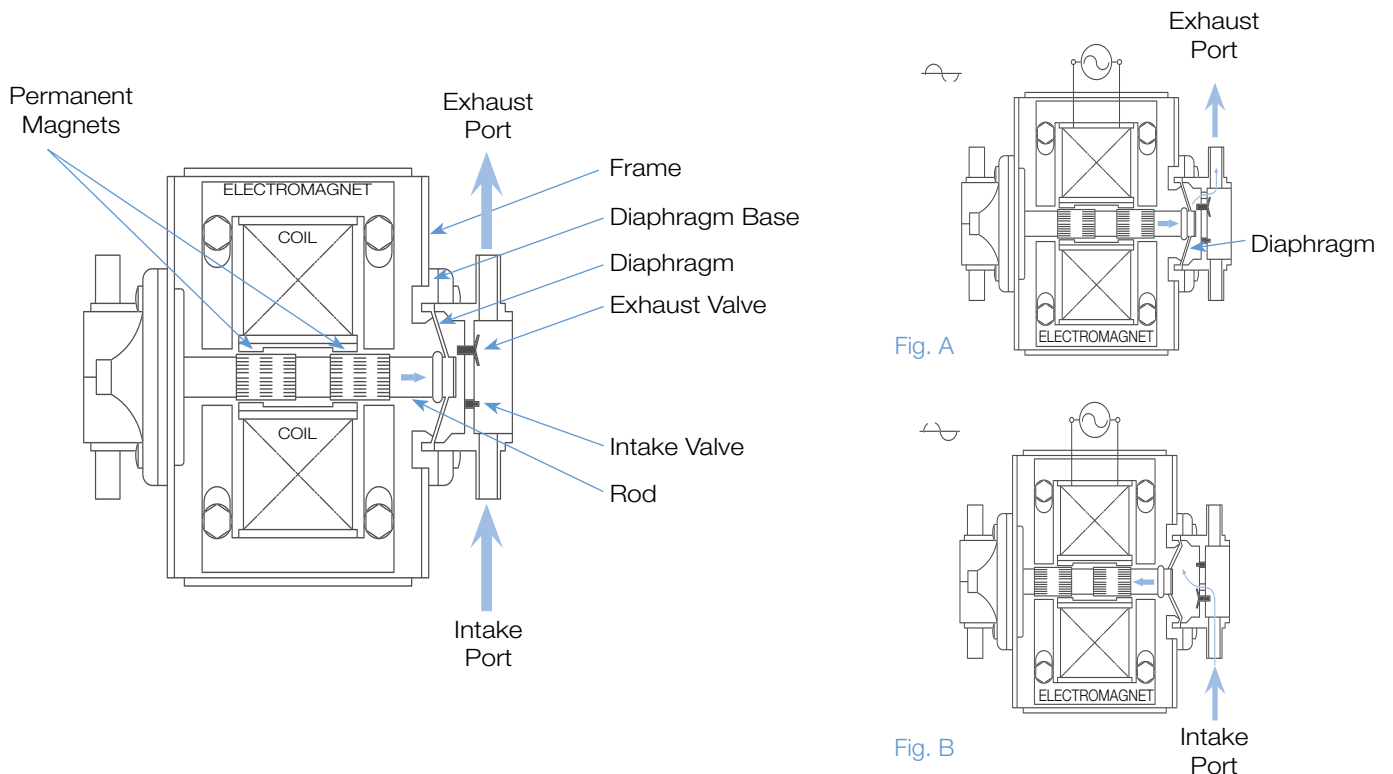

Linear Performance Overview

MODEL/ SERIES	MAX POWER Watts	FREE AIR FLOW				MAXIMUM PRESSURE				MAXIMUM VACUUM			
		CFM		LPM		psi		bar		inHg		mbar	
		50 Hz	60 Hz	50 Hz	60 Hz	50 Hz	60 Hz	50 Hz	60 Hz	50 Hz	60 Hz	50 Hz	60 Hz
DDL5	9.5	.45	.45	13	13	3.3	3.2	.23	.22				
DDL5BS	10	.39	.39	11	11	2.8	2.8	.19	.19	4.6	4.8	857	850
DDL5ES	10	.39	.39	11	11	2.8	2.8	.19	.19	4.6	4.8	857	850
DDL8	12	.81	.81	23	23	3.2	3.2	.22	.22	5.5	7.7	827	752
DDL8B	13	.81	.81	23	23	3.2	3.2	.22	.22				
DDL8BS	12	.81	.99	23	28	2.6	3.0	.18	.21	6.3	7.5	800	759
DDL15	20	.98	1.1	28	32	4.4	4.5	.30	.31	9.4	10.8	695	647
DDL15B	22	.98	1.1	28	32	4.4	4.5	.30	.31				
DBM20	15	.92	1.0	26	29	5.8	5.2	.40	.36	9.8	10.4	681	661
DBP25	20	1.2	1.4	35	39	5.0	5.0	.34	.34				
DBP40	40	2.4	2.1	67	59	4.4	5.8	.30	.40				
DBM30B	34	2.0	2.2	57	63	4.8	5.1	.33	.35	8.9	9.6	712	688
DDL30	46	2.3	1.9	65	54	5.1	5.4	.35	.37				
DDL30B	46	2.3	1.9	65	54	5.1	5.4	.35	.37				
DDL30BS	46	2.3	1.9	65	59	4.4	5.5	.30	.38	10.7	12.2	651	600
DBM40	46	2.6	2.0	74	56	5.4	6.2	.37	.43				
DDL40	46	2.6	2.3	76	65	5.8	5.9	.40	.41				
DDL40B	51	2.6	2.3	76	65	5.8	5.9	.40	.41				
DDL40BS	51	3.2	3.7	92	105	5.1	6.2	.35	.43	9.9	11.9	678	610
DBM60	71	3.3	3.4	95	96	6.2	6.3	.43	.44				
DBMS60	70	3.3		95		6.2		.43					
DBMS600	71		3.4		96		6.3		.44				
DDL60	70	3.6	2.8	102	79	6.1	6.3	.42	.43				
DDL80	95	3.9	4.2	111	120	7.0	7.0	.48	.48				
DBM80	92	4.1	4.2	117	118	6.6	7.2	.46	.50				
DBMS80	82	4.1		117		6.6		.46					
DBMS800	92		4.2		118		7.2		.50				
DBMX80	101	4.9	5.1	140	145	6.8	7.2	.47	.50				
DBMX100	124	5.3	5.5	150	155	7.8	7.9	.53	.54				
DBMX120	154	6.2	5.9	175	168	8.5	8.3	.59	.57				
DBMX150	170	9.2	8.5	260	240	6.1	6.3	.42	.43				
DBMX200	230	9.9	9.5	280	270	7.4	7.2	.51	.50				

Gas Compressors and Vacuum Pumps Performance

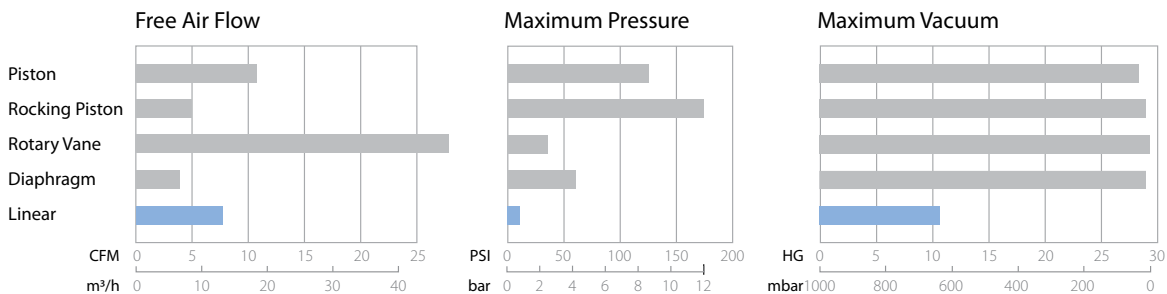

*Shown here are performance ranges of our positive displacement models.

Note: Performance shown on inside charts is for continuous operation. Higher performance is possible on an intermittent basis (10 min. on/10 min. off) for some of the models listed. Consult Factory.

Typical Applications



Environmental Applications

Tank aeration

Fish or lobster tanks located in pet stores, restaurants, or supermarkets require air to keep their contents alive. Tank location and size will dictate the type of compressor to be used.

Pond aeration

Pond aeration is done for two basic reasons. One is aquaculture, where large numbers of fish are “farmed” in a single pond. The second is ecological. As a pond or lake ages, it can lose its oxygen supply and may die. When air is introduced into a pond or lake, oxygen becomes plentiful again and life in and around the water can flourish.

Home aerobic sewage treatment

In some parts of the country where city sewerage is not available and high water tables exist, household waste must be treated aerobically. This means air is mixed into a solution which activates microbes that feed on the waste, speeding up the naturally occurring organic breakdown.



Medical Applications

Circulation therapy equipment

For patients who are confined to bed for an extended period in certain medical situations, such as post surgical recovery, it is necessary to keep a patient’s blood, which has a tendency to collect or “pool” in the limbs, moving. Compression therapy sleeves, designed to force the blood from the extremities back into the body where it can be utilized in the healing process, can solve this issue.

Air beds

Patients who are confined to bed for an extended period need a great deal of care. They must be moved to prevent bed sores, brought to a seated position to eat, and must have the moisture developed from perspiration removed. A specially designed air bed addresses all of these issues.



Other Applications

- Paper counting machines
- Blood cuff monitor
- Liquid agitation and mixing
- Medical nebulizer
- Air supply for leak test equipment
- Scientific and medical analysis equipment
- Inkjet printers
- Environmental monitoring and air sampling
- Solder removal
- Automotive emission test equipment





DDL5

3.2 psi max. pressure (.22 bar) 12.5 LPM open flow (60 Hz/120 V)

3.2 psi max. pressure (.22 bar) 12.5 LPM open flow (50 Hz/230 V)

DDL5BS-100/500, DDL5ES-100

2.8 psi max. pressure (.19 bar) 11.0 LPM open flow (60 Hz/120 V)

2.8 psi max. pressure (.19 bar) 11.0 LPM open flow (50 Hz/230 V)

4.8 inHg max. vacuum (850 mbar) 11.0 LPM open flow (60 Hz/120 V)

4.6 inHg max. vacuum (857 mbar) 11.0 LPM open flow (50 Hz/230 V)

Product Dimensions (inches, mm)

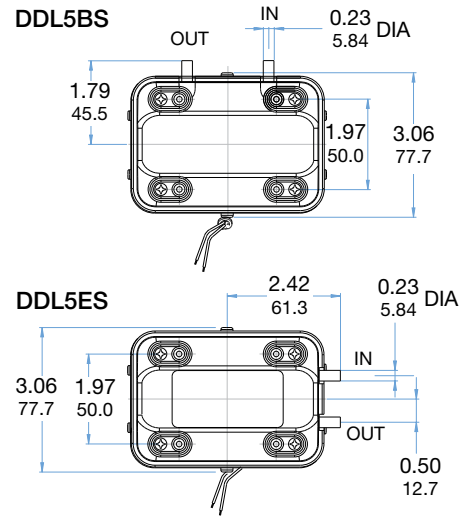
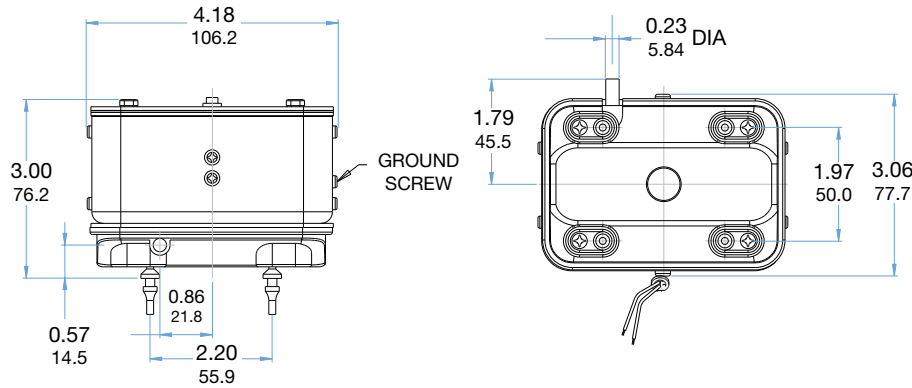

Product Specifications

Model Number	Operating Voltage Frequency (Hz)	Typical Operating Power (W)	Typical Operating Pressure (psi/bar)	Sound Level dB(a)	Net Wt. lb	kg
DDL5-101	120-60-1	9	0.57 / 0.04	33	1.9	0.88
DDL5-501	230-60/50-1	9	0.57 / 0.04	33	1.9	0.88
DDL5BS-101	120-60-1	8.7	0.57 / 0.04	33	1.9	0.88
DDL5BS-501	230-60/50-1	9	0.57 / 0.04	33	1.9	0.88
DDL5ES-101	120-60-1	8.7	0.57 / 0.04	33	1.9	0.88

- All 101 models include pigtail style electrical leads
- Low noise and vibration
- **CE** In compliance with the European Community's Machinery Directive
- DDL5-101 listed to **UL** 1450 air compressor and Canadian Standard C22.2 No. 68-92

Product Performance (U.S., Metric)

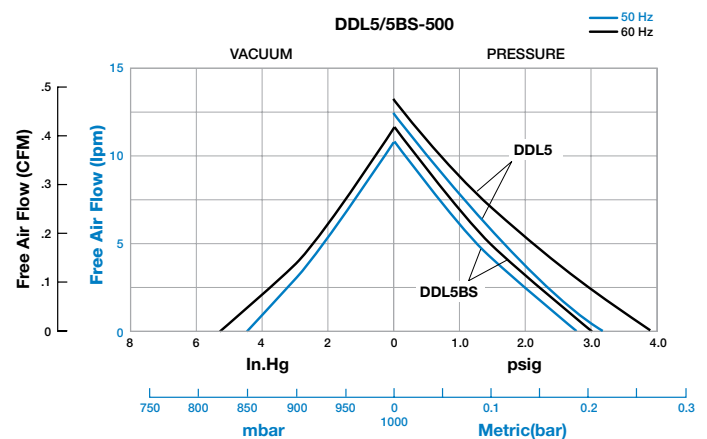
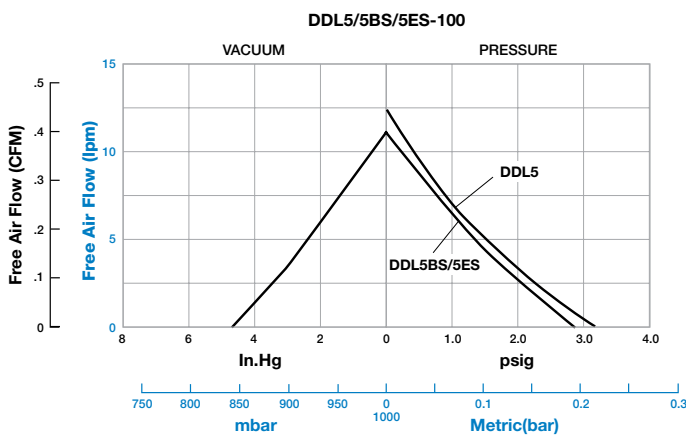



DDL8B

3.2 psi max. pressure (.22 bar) 23 LPM open flow (60 Hz)
2.6 psi max. pressure (.18 bar) 23 LPM open flow (50 Hz)

DDL8BS

3.0 psi max. pressure (.21 bar) 28 LPM open flow (60 Hz)
2.6 psi max. pressure (.18 bar) 23 LPM open flow (50 Hz)
7.5 inHg max. vacuum (759 mbar) 26 LPM open flow (60 Hz/120 V)
6.3 inHg max. vacuum (800 mbar) 21 LPM open flow (50 Hz/230 V)

DDL15B

4.4 psi max. pressure (.30 bar) 27 LPM open flow (50 Hz)
4.5 psi max. pressure (.32 bar) 32 LPM open flow (60 Hz)

Product Dimensions (inches, mm)

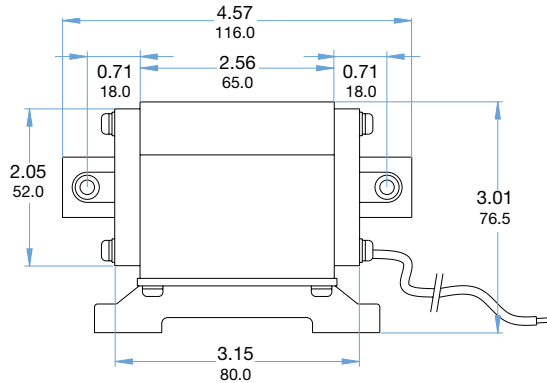
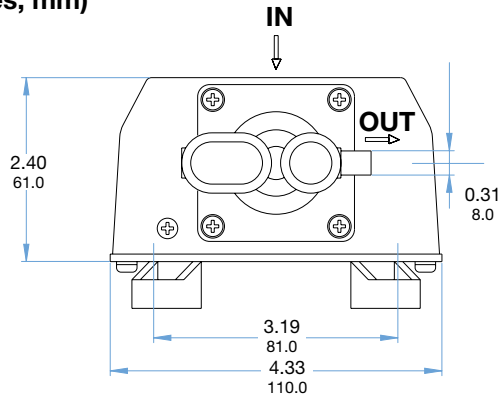

Product Specifications

Model Number	Operating Voltage Frequency (Hz)	Typical Operating Power (W)	Typical Operating Pressure (psi/bar)	Sound Level dB(a)	Net Wt.	
					lb	kg
DDL8B-101	120-60	12	1.42 / 0.10	40	2.4	1.1
DDL8B-804	230-50	10	1.42 / 0.10	40	2.4	1.1
DDL8BS-101	120-60:100-110-50	12/10	1.42 / 0.10	44	2.4	1.1
DDL15B-101	120-60	22	1.42 / 0.10	45	2.4	1.1
DDL15B-804	230-50	21	1.42 / 0.10	45	2.4	1.1

- All models shipped with pigtail wiring - 310 mm or 12 inch leads
- In compliance with the European Community's Machinery Directive
- Aluminum cover
- For limited space application
- Compact
- Vibration mounting for smooth operation

Product Performance (U.S., Metric)

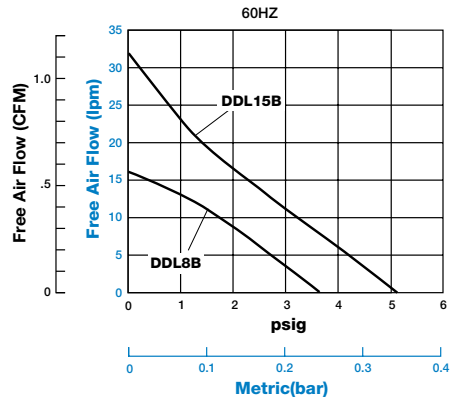
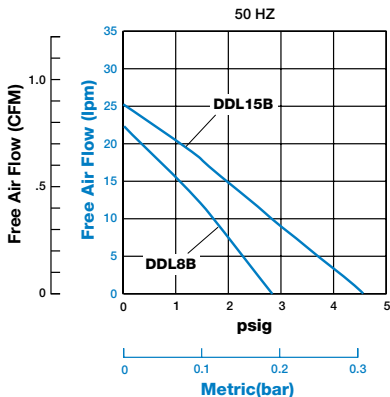



DDL8

3.2 psi max. pressure (.22 bar) 23 LPM open flow (60 Hz)
 3.2 psi max. pressure (.22 bar) 23 LPM open flow (50 Hz)
 7.7 inHg max vacuum (752 mbar) 23 LPM open flow (60 Hz)
 5.5 inHg max vacuum (827 mbar) 23 LPM open flow (50 Hz)

DDL15

4.5 psi max. pressure (.31 bar) 32 LPM open flow (60 Hz)
 4.4 psi max. pressure (.30 bar) 28 LPM open flow (50 Hz)
 10.8 inHg max vacuum (647 mbar) 32 LPM open flow (60 Hz)
 9.4 inHg max vacuum (695 mbar) 28 LPM open flow (50 Hz)

Product Dimensions (inches, mm)

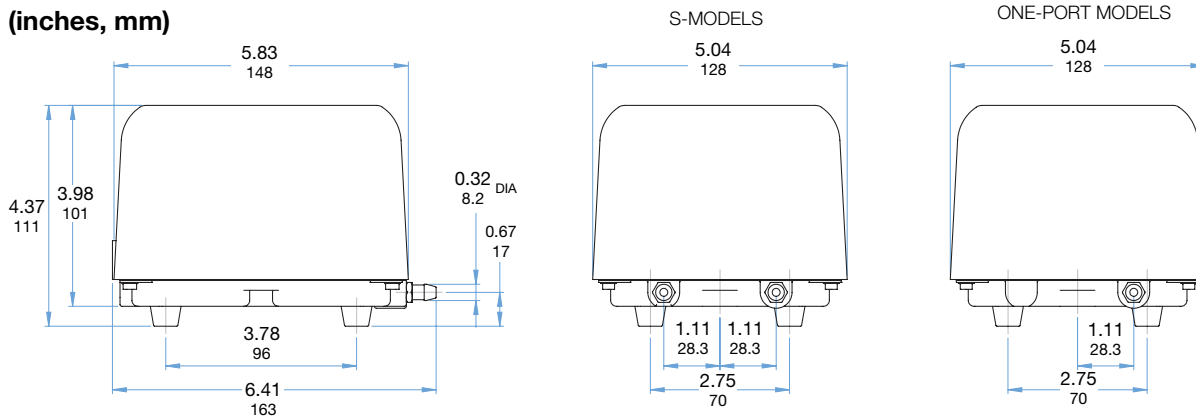

Product Specifications

Model Number	Operating Voltage Frequency (Hz)	Typical Operating Power (W)	Typical Operating Pressure (psi/bar)	Sound Level dB(a)	Net Wt.	
					lb	kg
DDL8-101	120-60	10	1.42 / 0.10	45	5.3	2.4
DDL8-801	230-50	10	1.42 / 0.10	45	5.3	2.4
DDL8S-101	120-60	10	1.42 / 0.10	45	5.3	2.4
DDL8S-801	230-50	10	1.42 / 0.10	45	5.3	2.4
DDL15-101	120-60	20	1.42 / 0.10	40	5.3	2.4
DDL15-801	230-50	20	1.42 / 0.10	40	5.3	2.4
DDL15S-101	120-60	20	1.42 / 0.10	40	5.3	2.4
DDL15S-801	230-50	20	1.42 / 0.10	40	5.3	2.4

- All 101 models include a 6 ft. cord/plug assembly; 801 models include a 1.8 metre cord with pigtailed (not shown in photo or drawing)
- Additional plug configurations available
- Low noise and vibration
- In compliance with the European Community's Machinery Directive
- DDL15 listed to **UL** Aquarium Equipment

Product Performance (U.S., Metric)

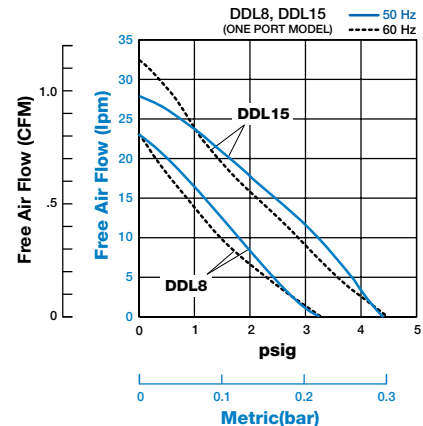
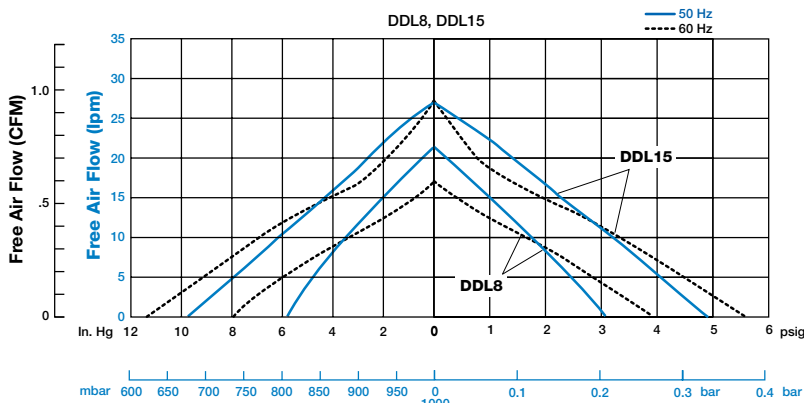



DBM20

5.2 psi max. pressure (.36 bar) 29 LPM open flow (60 Hz)
 5.8 psi max. pressure (.40 bar) 26 LPM open flow (50 Hz)
 10.4 inHg max vacuum (661 mbar) 29 LPM open flow (60 Hz)
 9.8 inHg max vacuum (681 mbar) 26 LPM open flow (50 Hz)

Product Dimensions (inches, mm)

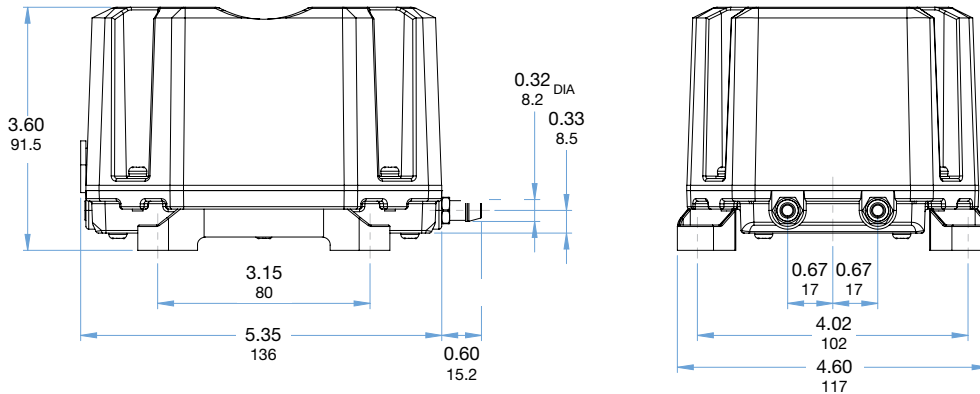

Product Specifications

Model Number	Operating Voltage Frequency (Hz)	Typical Operating Power (W)	Typical Operating Pressure (psi/bar)	Sound Level dB(a)	Net Wt.	
					lb	kg
DBM20-101	120-60	15	1.42 / 0.10	37	3.9	1.8
DBM20-801	230-50	15	1.42 / 0.10	37	3.9	1.8

- All models include pigtail style electrical leads
- Low noise and vibration
- DBM20-101 listed to **UL** 1450 air compressor/ vacuum pump and Canadian Standard C22.2 No 68-92
- **CE** In compliance with the European Community's Machinery Directive

Product Performance (U.S., Metric)

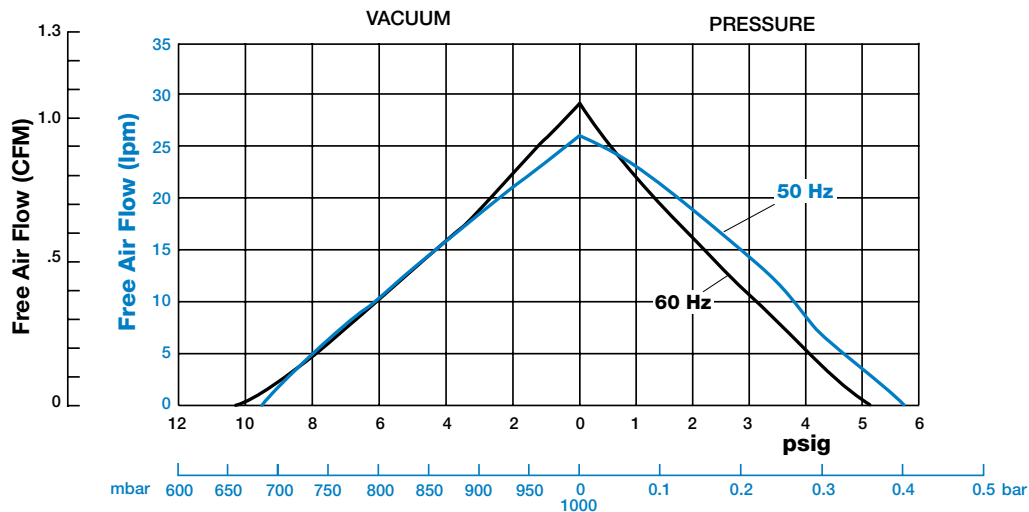



DBP25

5.0 psi max. pressure (.34 bar) 39 LPM open flow (60 Hz)
5.0 psi max. pressure (.34 bar) 35 LPM open flow (50 Hz)

Product Dimensions (inches, mm)

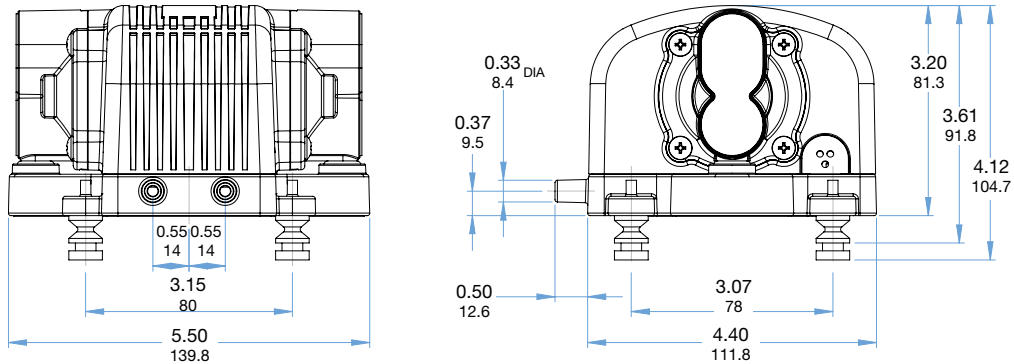

Product Specifications

Model Number	Operating Voltage Frequency (Hz)	Typical Operating Power (W)	Typical Operating Pressure (psi/bar)	Sound Level dB(a)	Net Wt.	
					lb	kg
DBP25-101	120-60	20	1.42 / 0.10	45	2.3	1.0
DBP25-801	230-50	18	1.42 / 0.10	45	2.3	1.0

- All models include pigtail style electrical leads
- Low noise and vibration
- DBP25-101 listed to **UL** 1450 air compressor/ vacuum pump and Canadian Standard C22.2 No 68-92
- **CE** In compliance with the European Community's Machinery Directive

Product Performance (U.S., Metric)

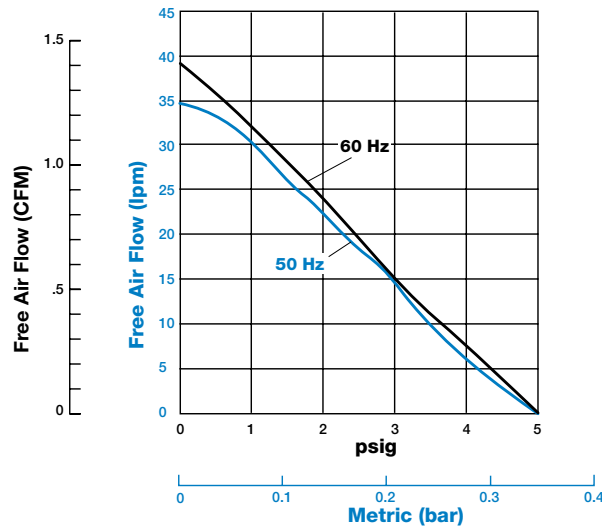



DBP40

5.8 psi max. pressure (.40 bar) 59 LPM open flow (60 Hz)

4.4 psi max. pressure (.30 bar) 67 LPM open flow (50 Hz)

Product Dimensions (inches, mm)

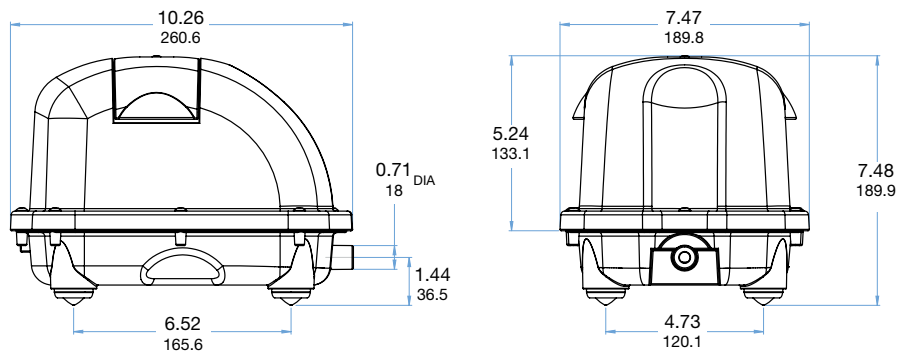

Product Specifications

Model Number	Operating Voltage Frequency (Hz)	Typical Operating Power (W)	Typical Operating Pressure (psi/bar)	Sound Level dB(a)	Net Wt.	
					lb	kg
DBP40-101	120-60	40	1.85 / 0.13	46	9.9	4.5
DBP40-801	230-50	31	1.85 / 0.13	46	9.9	4.5

- All models include pigtail style electrical leads
- Low noise and vibration
- DBP40-101 listed to **UL** 1450 air compressor/ vacuum pump and Canadian Standard C22.2 No 68-92
- **CE** In compliance with the European Community's Machinery Directive

Product Performance (U.S., Metric)

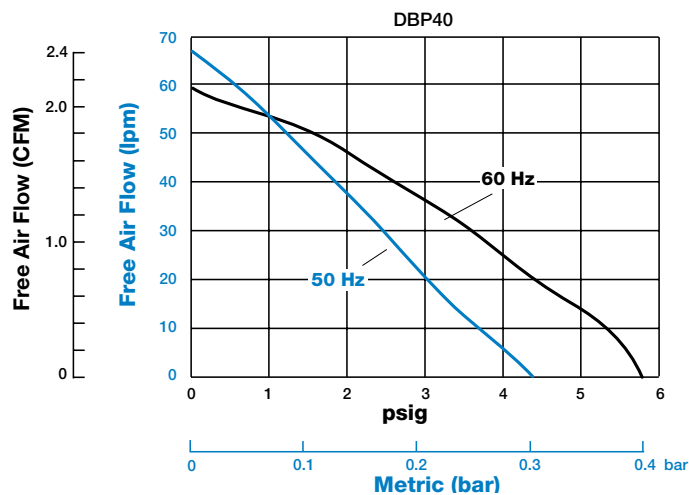

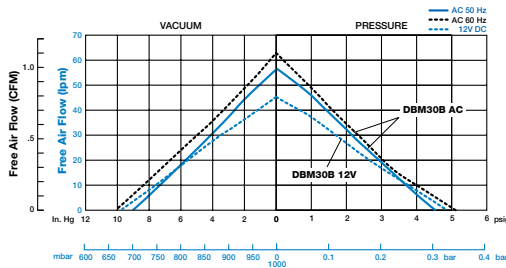

DBM30B

- 5.1 psi max. pressure (.35 bar) 63 LPM open flow (60 Hz)
- 4.8 psi max. pressure (.33 bar) 57 LPM open flow (50 Hz)
- 9.6 inHg max vacuum (688 mbar) 63 LPM open flow (60 Hz)
- 8.9 inHg max vacuum (712 mbar) 57 LPM open flow (50 Hz)

DBM30B 12 V

- 4.5 psi max. pressure (.31 bar) 45 LPM open flow
- 9.4 inHg max vacuum (695 mbar) 45 LPM open flow

Product Dimensions (inches, mm)

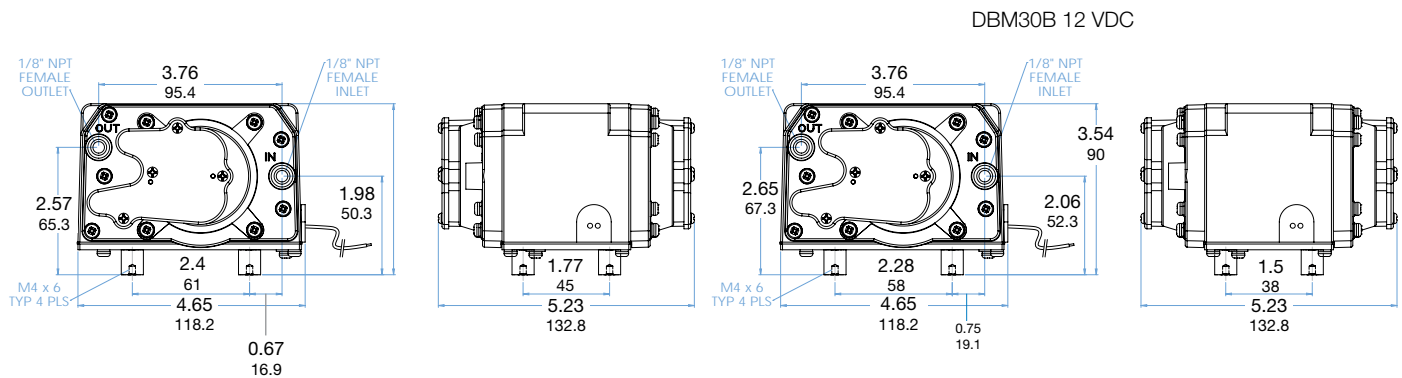

Product Specifications

Model Number	Operating Voltage Frequency (Hz)	Typical Operating Power (W)	Typical Operating Pressure (psi/bar)	Sound Level dB(a)	Net Wt.	
					lb	kg
DBM30B-101	120-60	28	1.85 / 0.13	48	3.8	1.7
DBM30B-801	230-50	24	1.85 / 0.13	48	3.8	1.7
DBM30B-201	12V DC	32	1.85 / 0.13	48	3.8	1.7

- All models include pigtail style electrical leads
- Low noise and vibration
- UL recognized to UL 1450 air compressor/ vacuum pump and Canadian Standard C22.2 No 68-92
- CE In compliance with the European Community's Machinery Directive

Product Performance (U.S., Metric)

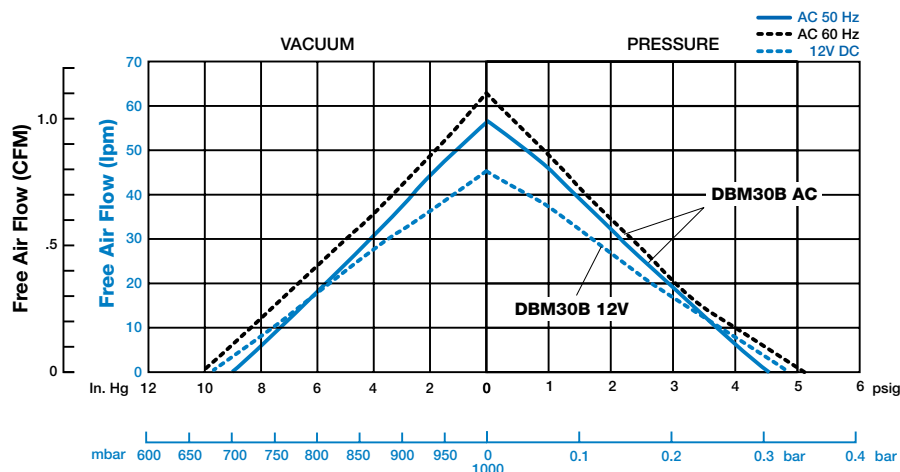



DDL30B

5.4 psi max. pressure (.37 bar) 54 LPM open flow (60 Hz)
5.1 psi max. pressure (.38 bar) 65 LPM open flow (50 Hz)

DDL30BS

5.5 psi max. pressure (.38 bar) 54 LPM open flow (60 Hz)
4.4 psi max. pressure (.30 bar) 65 LPM open flow (50 Hz)
12.2 inHg max. vacuum (600 mbar) 54 LPM open flow (60 Hz)
10.7 inHg max. vacuum (651 mbar) 92 LPM open flow (50 Hz)

DDL40B

5.9 psi max. pressure (.41 bar) 65 LPM open flow (60 Hz)
5.8 psi max. pressure (.40 bar) 76 LPM open flow (50 Hz)

DDL40BS

6.2 psi max. pressure (.43 bar) 105 LPM open flow (60 Hz)
5.1 psi max. pressure (.35 bar) 92 LPM open flow (50 Hz)
11.9 inHg max. vacuum (610 mbar) 105 LPM open flow (60 Hz)
9.9 inHg max. vacuum (678 mbar) 92 LPM open flow (50 Hz)

Product Dimensions (inches, mm)

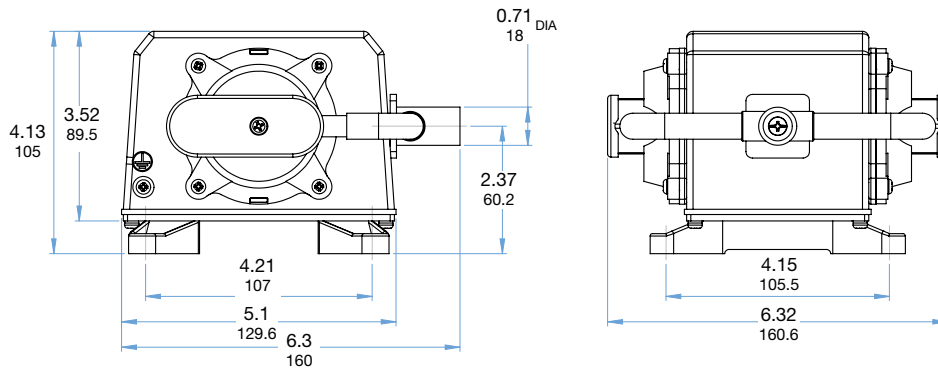

Product Specifications

Model Number	Operating Voltage Frequency (Hz)	Typical Operating Power (W)	Typical Operating Pressure (psi/bar)	Sound Level dB(a)	Net Wt.	
					lb	kg
DDL30B-101	120-60	43	1.85 / 0.13	40	6.4	2.9
DDL30B-804	230-50	32	1.85 / 0.13	40	6.4	2.9
DDL30BS-101	120-60:100-110-50	43	1.85 / 0.13	55	6.4	2.9
DDL30BS-804	230-50/60	32	1.85 / 0.13	55	6.4	2.9
DDL40B-101	120-60	48	1.85 / 0.13	45	6.4	2.9
DDL40B-804	230-50	40	1.85 / 0.13	45	6.4	2.9
DDL40BS-101	120-60:100-110-50	48	1.85 / 0.13	52	6.4	2.9

- All models shipped with pigtail wiring - 310 mm or 12 inch leads
- In compliance with the European Community's Machinery Directive
- Aluminum cover
- Compact for limited space application

Product Performance (U.S., Metric)

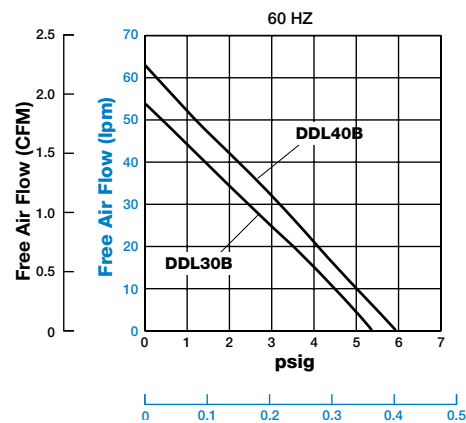
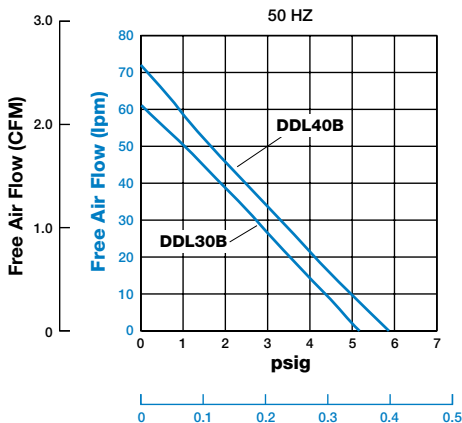



DBM40

6.2 psi max. pressure (.43 bar) 56 LPM open flow (60 Hz)
5.4 psi max. pressure (.37 bar) 74 LPM open flow (50 Hz)

DBM60

6.3 psi max. pressure (.44 bar) 96 LPM open flow (60 Hz)
6.2 psi max. pressure (.43 bar) 95 LPM open flow (50 Hz)

DBM80

7.2 psi max. pressure (.50 bar) 118 LPM open flow (60 Hz)
6.6 psi max. pressure (.46 bar) 117 LPM open flow (50 Hz)

DBMS60

6.2 psi max. pressure (.43 bar) 95 LPM open flow (50 Hz)

DBMS80

6.6 psi max. pressure (.46 bar) 117 LPM open flow (50 Hz)

DBMS600

6.3 psi max. pressure (.44 bar) 96 LPM open flow (60 Hz)

DBMS800

7.2 psi max. pressure (.50 bar) 118 LPM open flow (60 Hz)

Product Dimensions (inches, mm)

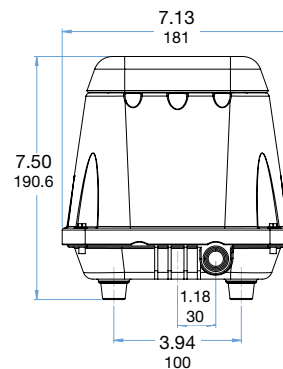
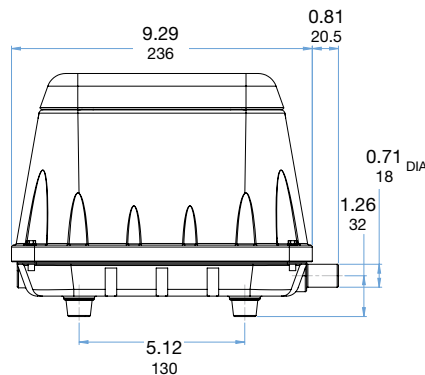

Product Specifications

Model Number	Operating Voltage Frequency (Hz)	Typical Operating Power (W)	Typical Operating Pressure (psi/bar)	Sound Level dB(a)	Net Wt.	
					lb	kg
DBM40-101	120-60	45	1.85 / 0.13	46	13.4	6.1
DBM40-801	230-50	43	1.85 / 0.13	46	13.4	6.1
DBM60-101	120-60	63	2.13 / 0.15	47	15.4	7.0
DBM60-801	230-50	61	2.13 / 0.15	47	15.4	7.0
DBM80-101	120-60	84	2.13 / 0.15	51	15.5	7.1
DBM80-801	230-50	78	2.13 / 0.15	51	15.5	7.1
DBMS60-801	230-50	61	2.13 / 0.15	47	15.4	7.0
DBMS80-801	230-50	78	2.13 / 0.15	51	15.5	7.1
DBMS600-101	120-60	63	2.13 / 0.15	47	15.4	7.0
DBMS800-101	120-60	84	2.13 / 0.15	51	15.5	7.1

- All models include pigtail style electrical leads
- Low noise and vibration
- **UL** listed to **UL** 1450 air compressor/vacuum pump and Canadian Standard C22.2 No 68-92 *
- **CE** In compliance with the European Community's Machinery Directive **
- "S" models include diaphragm over-stroke protection

* **UL/CSA** listing in process (for the DBMS60-801 & DBMS80-801)

** **CE** compliance listing in process (for the DBMS600-101 & DBMS800-101)

Product Performance (U.S., Metric)

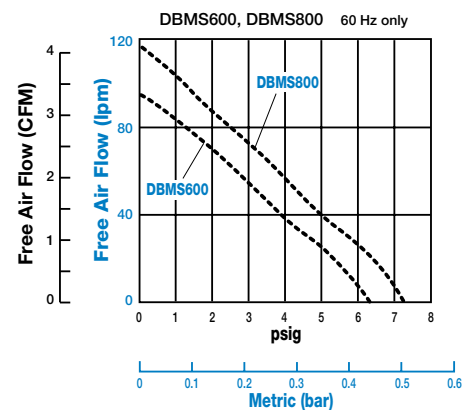
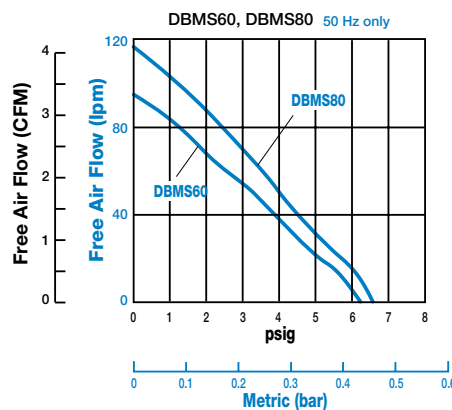
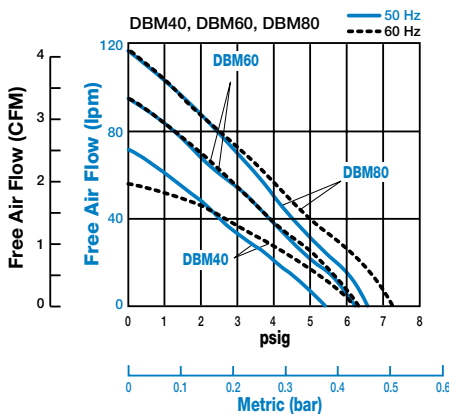



DDL30

5.4 psi max. pressure (.37 bar) 54 LPM open flow (60 Hz)
5.1 psi max. pressure (.35 bar) 65 LPM open flow (50 Hz)

DDL40

5.9 psi max. pressure (.41 bar) 65 LPM open flow (60 Hz)
5.8 psi max. pressure (.40 bar) 76 LPM open flow (50 Hz)

DDL60

6.3 psi max. pressure (.43 bar) 79 LPM open flow (60 Hz)
6.1 psi max. pressure (.42 bar) 102 LPM open flow (50 Hz)

DDL80

7.0 psi max. pressure (.48 bar) 120 LPM open flow (60 Hz)
7.0 psi max. pressure (.48 bar) 111 LPM open flow (50 Hz)

Product Dimensions (inches, mm)

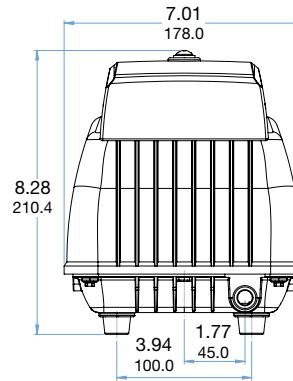
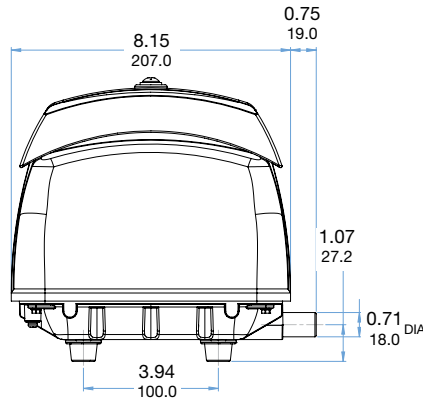

Product Specifications

Model Number	Operating Voltage Frequency (Hz)	Typical Operating Power (W)	Typical Operating Pressure (psi/bar)	Sound Level dB(a)	Net Wt.	
					lb	kg
DDL30-101	120-60	43	1.85 / 0.13	40	12	5.4
DDL30-801	230-50	32	1.85 / 0.13	40	12	5.4
DDL40-101	120-60	45	1.85 / 0.13	41	12	5.4
DDL40-801	230-50	41	1.85 / 0.13	38	12	5.4
DDL60-101	120-60	64	2.13 / 0.15	50	13	6.3
DDL60-801	230-50	64	2.13 / 0.15	40	13	6.3
DDL80-101	120-60	84	2.13 / 0.15	52	13	6.3
DDL80-801	230-50	91	2.13 / 0.15	40	13	6.3

- All 101 models include a 6 ft. cord/plug assembly; 801 models include a 1.8 metre cord with pigtailed (not shown in photo or drawing)
- Additional plug configurations available
- CE In compliance with the European Community's Machinery Directive
- **UL** listed to **UL** 1450 air compressor/vacuum pump and Canadian Standard C22.2 No 68-92
- Quiet operation
- Drop into existing system
- Aluminum housing for better ventilation

Product Performance (U.S., Metric)

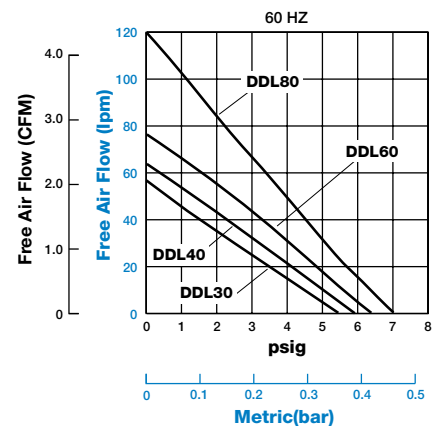
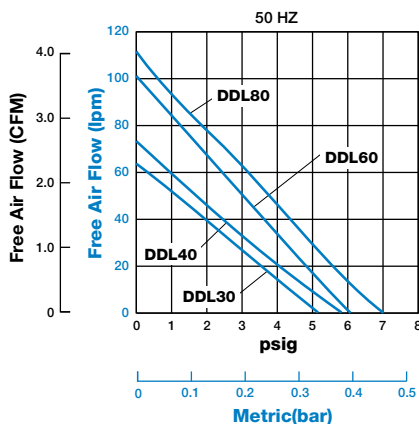



DBMX80

7.2 psi max. pressure (.50 bar) 145 LPM open flow (60 Hz)
6.8 psi max. pressure (.47 bar) 140 LPM open flow (50 Hz)

DBMX100

7.9 psi max. pressure (.54 bar) 155 LPM open flow (60 Hz)
7.8 psi max. pressure (.53 bar) 150 LPM open flow (50 Hz)

DBMX120

8.3 psi max. pressure (.57 bar) 168 LPM open flow (60 Hz)
8.5 psi max. pressure (.59 bar) 175 LPM open flow (50 Hz)

Product Dimensions (inches, mm)

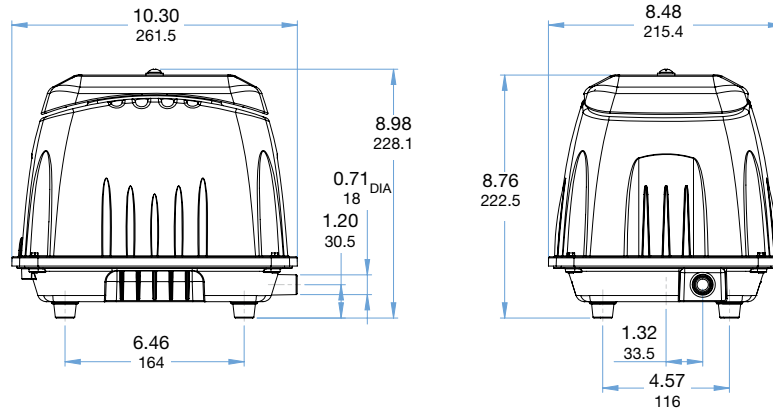

Product Specifications

Model Number	Operating Voltage Frequency (Hz)	Typical Operating Power (W)	Typical Operating Pressure (psi/bar)	Sound Level dB(a)	Net Wt.	
					lb	kg
DBMX80-101	120-60	71	2.56 / 0.18	50	16.5	7.5
DBMX80-801	230-50	68	2.56 / 0.18	50	16.5	7.5
DBMX100-101	120-60	94	2.56 / 0.18	50	16.5	7.5
DBMX100-801	230-50	87	2.56 / 0.18	50	16.5	7.5
DBMX120-101	120-60	128	2.84 / 0.20	46	19.4	8.8
DBMX120-801	230-50	110	2.84 / 0.20	46	19.4	8.8

- All models include pigtail style electrical leads
- Low noise and vibration
- Over-stroke protection
- **UL** listed to **UL** 1450 air compressor/vacuum pump and Canadian Standard C22.2 No 68-92
- **CE** In compliance with the European Community's Machinery Directive

Product Performance (U.S., Metric)

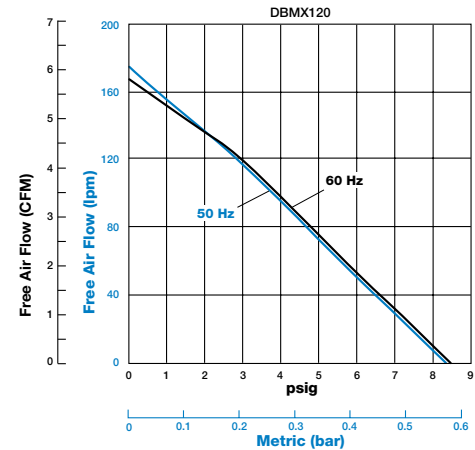
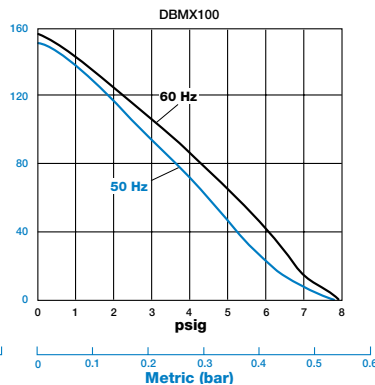
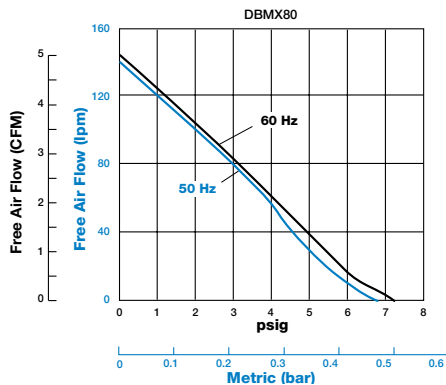



DBMX150

6.3 psi max. pressure (.43 bar) 240 LPM open flow (60 Hz)
6.1 psi max. pressure (.42 bar) 260 LPM open flow (50 Hz)

DBMX200

7.2 psi max. pressure (.50 bar) 270 LPM open flow (60 Hz)
7.4 psi max. pressure (.51 bar) 280 LPM open flow (50 Hz)

Product Dimensions (inches, mm)

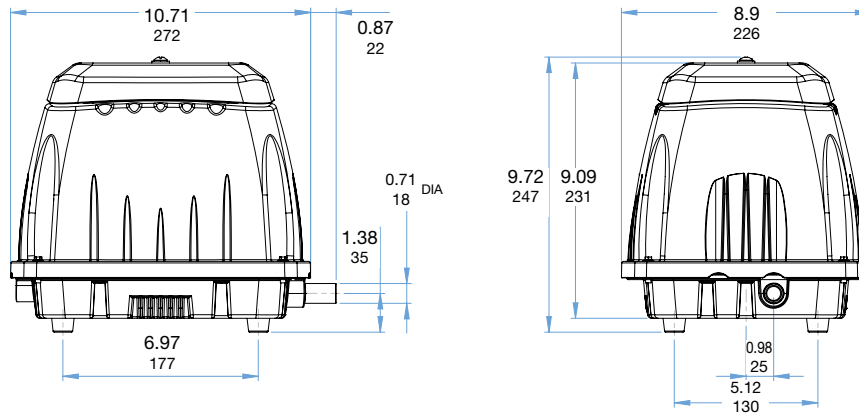

Product Specifications

Model Number	Operating Voltage Frequency (Hz)	Typical Operating Power (W)	Typical Operating Pressure (psi/bar)	Sound Level dB(a)	Net Wt. lb	Net Wt. kg
DBMX150-101	120-60	134	2.84 / 0.20	48	26.2	11.9
DBMX150-801	230-50	130	2.84 / 0.20	48	26.2	11.9
DBMX200-101	120-60	190	2.84 / 0.20	48	26.2	11.9
DBMX200-801	230-50	186	2.84 / 0.20	48	26.2	11.9

- All models include pigtail style electrical leads
- Low noise and vibration
- Over-stroke protection
- **CE** In compliance with the European Community's Machinery Directive

Product Performance (U.S., Metric)

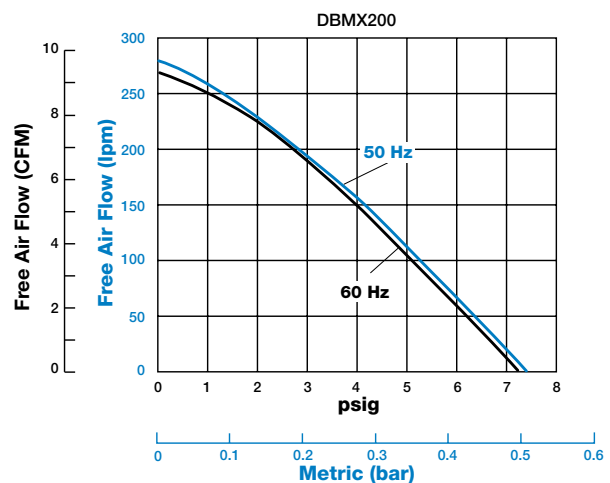
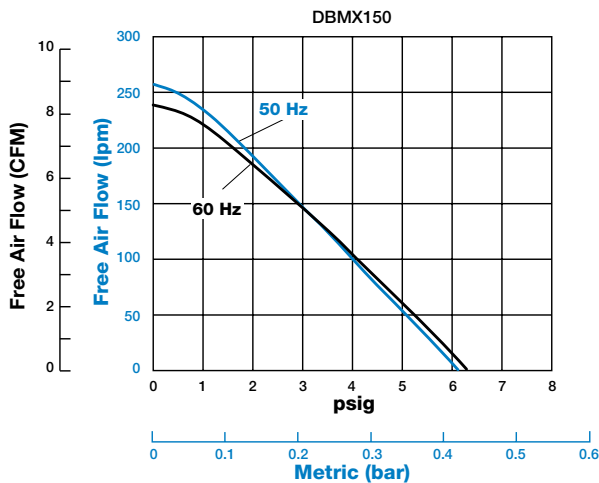



DBM40

6.2 psi max. pressure (.43 bar) 56 LPM open flow (60 Hz)

DBM60

6.3 psi max. pressure (.44 bar) 96 LPM open flow (60 Hz)

DBM80

7.2 psi max. pressure (.50 bar) 118 LPM open flow (60 Hz)

Product Dimensions (inches, mm)

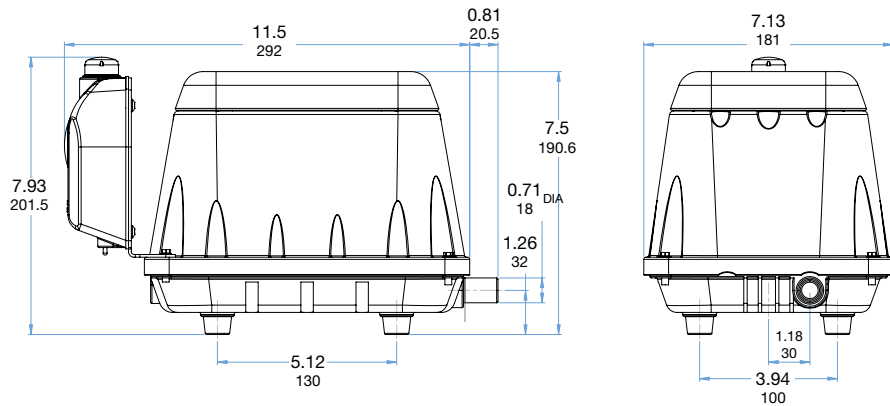

Product Specifications

Model Number	Operating Voltage Frequency (Hz)	Typical Operating Power (W)	Typical Operating Pressure (psi/bar)	Sound Level dB(a)	Net Wt.	
					lb	kg
DBM40-175	120-60	45	1.85 / 0.13	46	14.7	6.7
DBM60-175	120-60	63	2.13 / 0.15	47	16.7	7.6
DBM80-175	120-60	84	2.13 / 0.15	51	16.8	7.6

- All models include pigtail style electrical leads
- Low noise and vibration
- **UL** listed to **UL** 1450 air compressor/vacuum pump and Canadian Standard C22.2 No 68-92
- **CE** In compliance with the European Community's Machinery Directive
- All models include low pressure or low and high pressure alarms
- Alarm system includes buzzer and warning light
- Alarms include On, Mute, and Test Mode switches
- Low pressure < 1 psi
- High pressure > 4 psi

Product Performance (U.S., Metric)

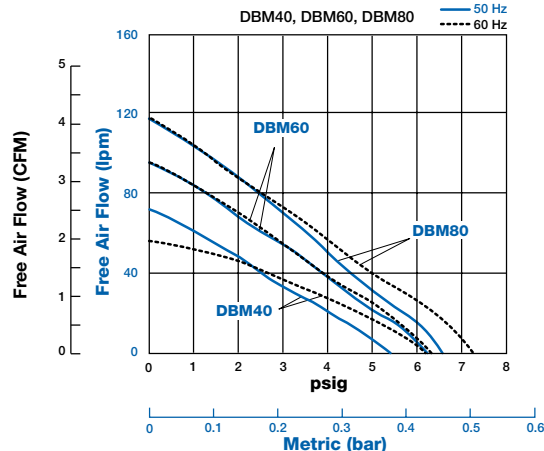



DBMX80

7.2 psi max. pressure (.50 bar) 145 LPM open flow (60 Hz)

DBMX100

7.9 psi max. pressure (.54 bar) 155 LPM open flow (60 Hz)

Product Dimensions (inches, mm)

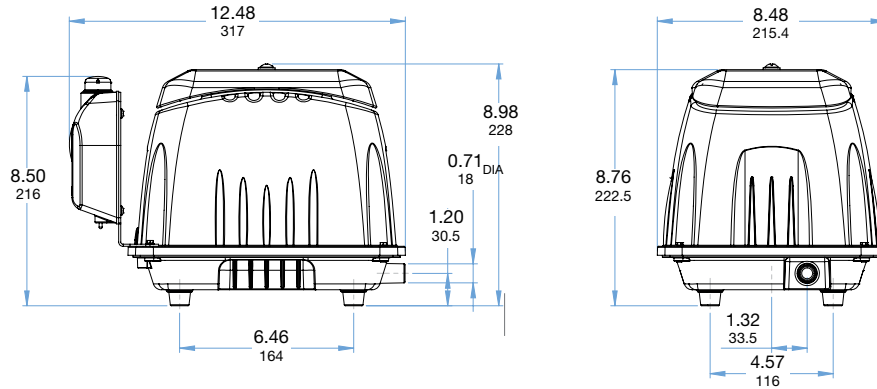

Product Specifications

Model Number	Operating Voltage Frequency (Hz)	Typical Operating Power (W)	Typical Operating Pressure (psi/bar)	Sound Level dB(a)	Net Wt. lb	Net Wt. kg
DBMX80-175	120-60	71	2.56 / 0.18	50	20.7	9.4
DBMX100-175	120-60	94	2.56 / 0.18	50	20.7	9.4

- All models include pigtail style electrical leads
- Low noise and vibration
- **UL** listed to **UL** 1450 air compressor/vacuum pump and Canadian Standard C22.2 No 68-92
- **CE** In compliance with the European Community's Machinery Directive
- All models include low pressure or low and high pressure alarms
- Alarm system includes buzzer and warning light
- Alarms include On, Mute, and Test Mode switches
- Low pressure < 1psi
- High pressure > 4psi

Product Performance (U.S., Metric)

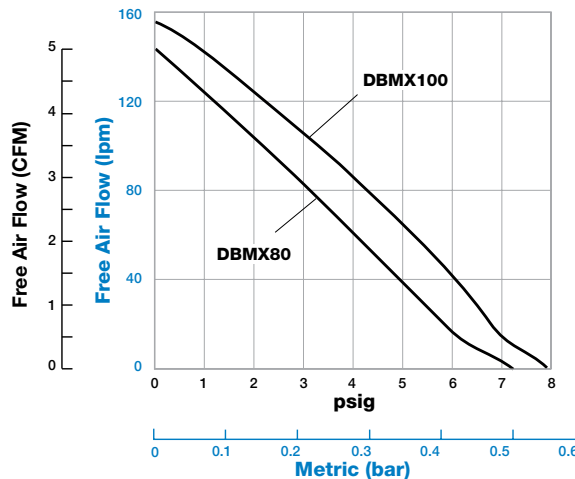



Gast Manufacturing, Inc.

A Unit of IDEX Corporation
Post Office Box 97
2300 M-139 Highway
Benton Harbor, Michigan 49023-0097
Phone 269-926-6171
Fax 269-925-8288
www.gastmfg.com

Gast Hong Kong

Room 6, 9/F, New Commerce Centre
19 On Sum Street, Shatin
Hong Kong
Phone 852-2690-1008
Fax 852-2690-1012

Gast Group Ltd.

A Unit of IDEX Corporation
Unit 11, The I O Centre
Nash Road
Redditch, B98 7AS
United Kingdom
Phone +44 (0)1527-504040
Fax +44 (0)1527-525262